

COUPLINGS

PRODUCT	PAGE
INDEX	C-1, C-2
COUPLING PRODUCTS	C-3
COUPLING COMPARISON	C-4
Martin-FLEX®	C-5
Selection Procedure	C-6
Power Ratings	C-7
Styles and Configuration	C-8
Dimensions F40 — F100	C-9
Dimensions F110 — F250	C-10
Spacer Couplings	C-11
Installation	C-12
Service Factors	C-13
HRC COUPLINGS	C-14
Selection Procedure	C-15
Dimensions 70 — 280	C-16
FLEXIBLE JAW COUPLINGS	C-17
Dimensions	C-18
Stock Jaw Selection Procedure	C-19
Stock Jaw Coupling Spiders	C-20
Stock Jaw Coupling Bore and Keyway Chart	C-21
Stock Jaw Selection and Power Ratings	C-22
RIGID COUPLINGS SELECTION AND DIMENSIONS	C-23
Installation	C-24
QUADRA-FLEX COUPLINGS	C-25
QUADRA-FLEX 4-WAY FLEXING	C-26
Styles	C-27
Sleeve Selection	C-28, C-29

COUPLINGS

PRODUCT	PAGE
Selection Procedure	C-30
Service Factors	C-31
Coupling Ratings	C-32
Sleeve Selection Chart	C-33
Hytrek Selection Chart	C-34
Quadra-flex Sleeves Dimensions	C-35
Quadra-flex Type J flange Dimensions	C-36
Quadra-flex Type S flange Dimensions	C-37
Quadra-flex Type S flanges (finished bores)	C-38
Keyseat Dimensions	C-39
Quadra-flex Type B flange Dimensions	C-40
TYPE SC SPACER COUPLING	C-41
Type SC flange Dimensions	C-42
Type SC Spacer hub bores	C-43
Between shaft spacing	C-44
Installation	C-45
ROLLER CHAIN COUPLING	C-46
Stock Roller Chain Dimensions	C-47
Roller Chain Coupling Selection	C-48
MRC Gear Coupling Features	C-49
MRC GEAR COUPLING	C-50
Gear Coupling Dimensions (finished bore)	C-51
Gear Coupling Dimensions	C-52
Gear Coupling for Standard IEC Motors	C-53
Notes	C-54



Whatever Your Need For Couplings Martin Has Them

Martin Offers a Complete Lines of Jaw Couplings— Completely Interchangeable.

Martin **-Flex®** — Today's Most Advanced Coupling. For High Strength, Better Balance, Easy Installation, and the Strong Shaft Fit of the Taper Bushing.

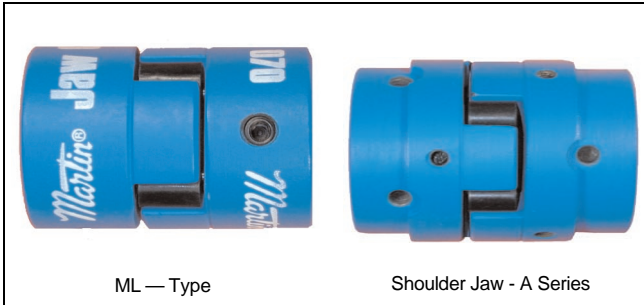

For the Most Complete Line of British Standard Chain Couplings Available.

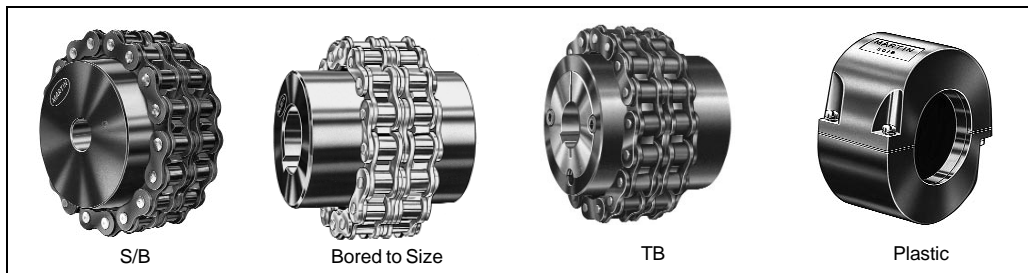

Martin **QUADRA-FLEX®** • A Proven Design Which Offers Long Life, Torsional Flexibility, Ease of Installation, and Withstands Misalignment, Shock, and Vibration.

(Available in Fall of 2000)



Martin's HRC Coupling •

General purpose coupling for quick and easy assembly.

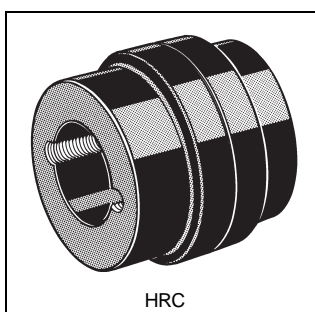

Martin's MRC® Gear Coupling •

A complete line of steel gear and plastic sleeve components.



Coupling Comparison



Couplings Comparison Chart

Allowable Type	Connecting Medium	Max. Nom. kW Per 100 RPM	Max. RPM	Bore Range	Misalignment	
					Angle	Parallel
CHAIN	ROLLER CHAIN	525	5000	10 — 155	2°	,038
JAW	ELASTOMERIC SPIDER	2,7	3600	3 — 70	1°	,038
Martin-FLEX®	ELASTOMERIC TYRE	154	4500	10 — 190	4°	1,1 — 6,6
QUADRA-FLEX®	ELASTOMERIC SLEEVE	85	9200	12,7 — 152,4	,33°	1,6
HRC	ELASTOMERIC SPIDER	33	3600	10 — 100	1°	0,3-0,5
GEAR	PLASTIC SLEEVE	4,3	7500	12 — 65	2°	+/- 0,4
RIGID	DIRECT CONNECTION	118	4500	11 — 125 TB	Need good alignment	

Dimensions in millimeters unless otherwise specified.

Type	Shock Load Capacity	Vibration Dampening	Temperature-Range	
			Range (Low)	Celsius (High)
CHAIN	NONE	NONE	-35°C	+120°C
JAW	MODERATE	MODERATE	-40°C	+100°C *1
Martin-FLEX®	EXCELLENT	EXCELLENT	-50°C	+70°C *2
QUADRA-FLEX®	EXCELLENT	EXCELLENT	-40°C	+135°C *3
		MODERATE	-65°C	+120°C *4
HRC	MODERATE	MODERATE	-40°C	+100°C *4
GEAR	POOR	POOR	-25°C	+100°C *2
RIGID	NONE	NONE	HIGH	HIGH

- ★1 With Hytrel® Spider
- ★2 Neoprene Element
- ★3 TPR Sleeve
- ★4 With EPDM Sleeve

Flexible Tyre

Highly resilient flexible tyre cushions shock loads, smoothing out load between driving and driven machines. Enables high levels of misalignment to be accommodated.

Easy Installation

Radially split tyre facilitates easy installation and removal without disturbing driving or driven shafts.

Maintenance and Lubrication

Lubrication
No maintenance or lubrication is required, visual inspection is all that is necessary.

Taper Flanges

Made from high grade S.G. iron, versatile design enable easy positioning on the shafts. The clamping system prevents relative movement between flexible tyre and flange.

Taper Bush

Provides a wide range of bore diameters, and enables easy assembly to shafts.

Tension Member

Cross piled synthetic tension member enables torque to be transmitted in either direction.

Elastomeric Compound

Available in either natural rubber or fire-resistant and anti-static chloroprene. Provides the shape and damping of the tyre.

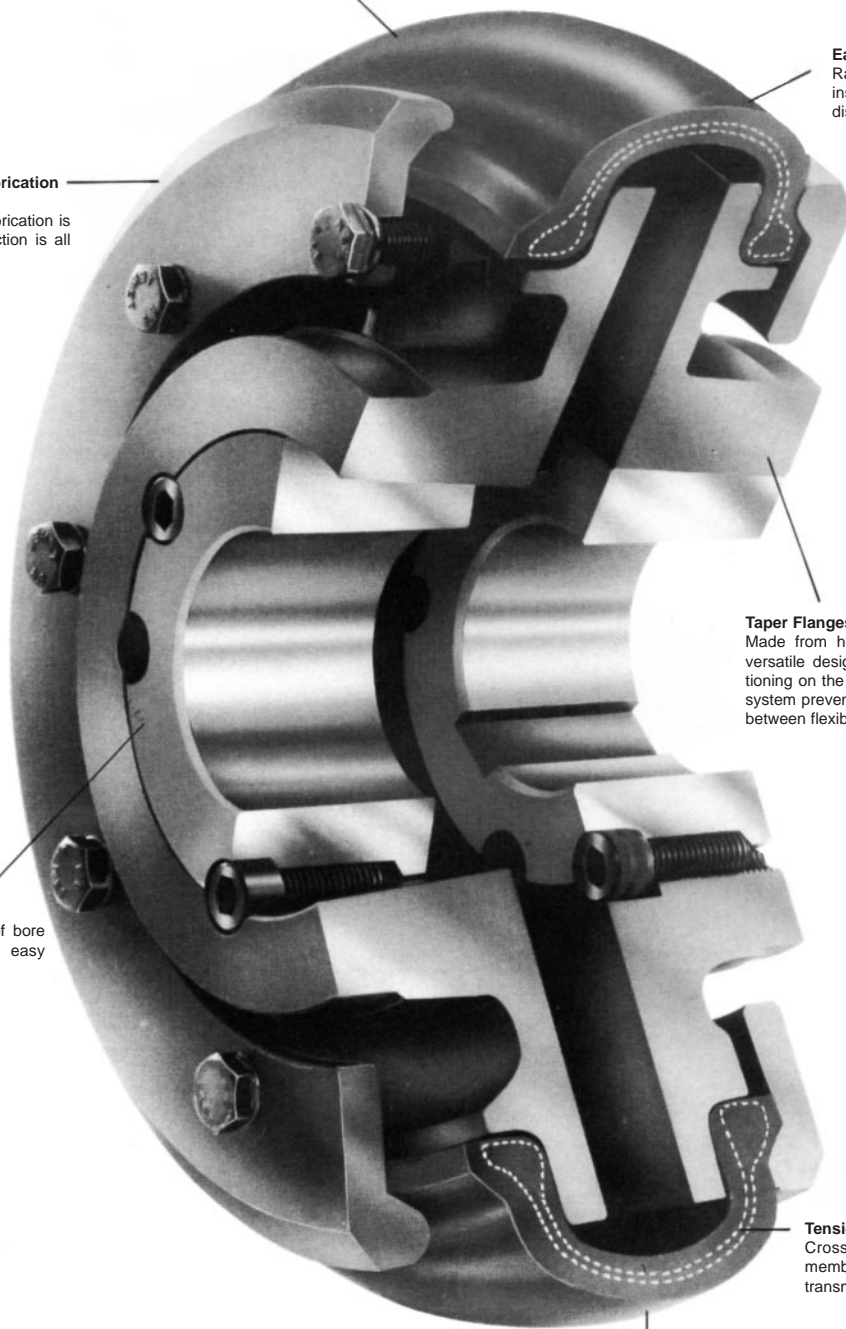

Martin-Flex couplings provide all the desirable features of an ideal flexible coupling, including Taper Bush fixing. The Martin-Flex coupling is a 'torsionally elastic' coupling offering versatility to designers and engineers with a choice of flange combinations to suit most applications.

The flanges are available in either F (face) or H (hub) Taper Bush fitting or bored to size.

With the addition of a spacer flange the coupling can be used to accommodate standard distance between shaft ends and facilitate pump maintenance.

Martin-Flex couplings can accommodate simultaneous maximum misalignment in all planes without imposing undue loads on adjacent bearings and the excellent shock-absorbing properties of the flexible tyre reduce vibration and torsional oscillation.

Martin-Flex tyres are available in natural rubber compounds for use in ambient temperatures between -50°C and +50°C. Chloroprene rubber compounds are available for use in adverse operating conditions (e.g. oil or grease contamination) and can be used in temperatures of -15°C to +70°C. The chloroprene component should also be used when fire-resistance and anti-static (F.R.A.S.) properties are required.

SELECTION

1. Service Factor

Determine the required Service Factor from table below.

2. Design Power

Multiply the normal running power by the service factor. This gives the design power which is used as a basis for selecting the coupling.

3. Coupling Size

Refer to Power Ratings table page C-7 and from the appropriate speed read across until a power greater than that required in step (b) is found.

The size of Martin-Flex coupling required is given at the head of that column.

4. Bore Size

Check for Dimensions table page C-9, C-10 that chosen flanges can accommodate required bores.

EXAMPLE

A Martin-Flex coupling is required to transmit 50kW from an A.C. electric motor which runs at 1440 rev/min to a rotary screen for 10 hours per day. The motor shaft is 60mm diameter and the screen shaft is 55mm diameter. Taper Bush is required.

1. Service Factor

The appropriate service factor is 1,3.

2. Design Power

Design Power = 50 x 1,3 = 65kW.

3. Coupling Size

By reading across from 1440 rev/min in the power ratings table the first power figure to exceed the required 65kW in step(b) is 75,4kW. The size of coupling is F90 Martin-Flex.

4. Bore Size

By referring to the dimensions table it can be seen that both shaft diameters fall within the bore range available.

SERVICE FACTORS

SPECIAL CASES For applications where substantial shock, vibration and torque fluctuations occur, and for reciprocating machines (e.g. internal combustion engines, piston pumps and compressors) refer to Martin with full machine details for analysis.	Type of Driven Unit					
	Electric Motors Steam Turbines			Internal Combustion Engines Steam Engines Water Turbines		
	Hours per day duty			Hours per day duty		
Type of Driven Machine	10 and under	over 10 to 16 incl.	over 16	10 and under	over 10 to 16 incl.	over 16
CLASS 1 Agitators, Brewing machinery, Centrifugal compressors and pumps. Belt conveyors, Dynamometers, Lineshafts, Fans up to 7,5kW. Blowers and exhausters (except positive displacement), Generators.	0,8	0,9	1,0	1,3	1,4	1,5
CLASS 2* Clay working machinery, General machine tools, paper mill beaters and winders, Rotary pumps, Rubber extruders, Rotary screens, Textile machinery, Marine propellers and Fans over 7,5kw.	1,3	1,4	1,5	1,8	1,9	2,0
CLASS 3* Bucket elevators, Cooling tower fans, Piston compressors and pumps, Foundry machinery, Metal presses, Paper mill calenders, Hammer mills, Presses and pulp grinders, Rubber calenders, Pulverizers and Positive displacement blowers.	1,8	1,9	2,0	2,3	2,4	2,5
CLASS 4* Reciprocating conveyors, Gyrotory crushers, Mills (ball, pebble and rod), Rubber machinery (Banbury mixers and mills) and Vibratory screens.	2,3	2,4	2,5	2,8	2,9	3,0

*It is recommended that keys (with top clearance if in Taper bushes) are fitted on application where load function is expected.

+ Couplings for use with internal combustion engines may require special consideration, such as a flywheel configuration. Consult Martin for specifications.

POWER RATINGS (kW)

Speed rev/min	Coupling Size														
	F40	F50	F60	F70	F80	F90	F100	F110	F120	F140	F160	F180	F200	F220	F250
100	0,25	0,69	1,33	2,62	3,93	5,24	7,07	9,16	13,9	24,3	39,5	65,7	97,6	121	154
200	0,50	1,38	2,66	5,24	7,85	10,5	14,1	18,3	27,9	48,7	79,0	131	195	243	307
300	0,75	2,07	3,99	7,85	11,8	15,7	21,2	27,5	41,8	73,0	118	197	293	364	461
400	1,01	2,76	5,32	10,5	15,7	20,9	28,3	36,6	55,7	97,4	158	263	391	486	615
500	1,26	3,46	6,65	13,1	19,6	26,2	35,3	45,8	69,6	122	197	328	488	607	768
600	1,51	4,15	7,98	15,7	23,6	31,4	42,4	55,0	83,6	146	237	394	586	729	922
700	1,76	4,84	9,31	18,3	27,5	36,6	49,5	64,1	97,5	170	276	460	684	850	1076
720	1,81	4,98	9,57	18,8	28,3	37,7	50,9	66,0	100	175	284	473	703	875	1106
800	2,01	5,53	10,6	20,9	31,4	41,9	56,5	73,3	111	195	316	525	781	972	1229
900	2,26	6,22	12,0	23,6	35,3	47,1	63,6	82,5	125	219	355	591	879	1093	1383
960	2,41	6,63	12,8	25,1	37,7	50,3	67,9	88,0	134	234	379	630	937	1166	1475
1000	2,51	6,91	13,3	26,2	39,3	52,4	70,7	91,6	139	243	395	657	976	1215	1537
1200	3,02	8,29	16,0	31,4	47,1	62,8	84,9	110	167	292	474	788	1172		
1400	3,52	9,68	18,6	36,6	55,0	73,3	99,0	128	195	341	553	919			
1440	3,62	9,95	19,1	37,7	56,5	75,4	102	132	201	351	568	945			
1600	4,02	11,1	21,3	41,9	62,8	83,8	113	147	223	390	632				
1800	4,52	12,4	23,9	47,1	70,7	94,2	127	165	251	438					
2000	5,03	13,8	26,6	52,4	78,5	105,5	141	183	279						
2200	5,53	15,2	29,3	57,6	86,4	115	155	202							
2400	6,03	16,6	31,9	62,8	94,2	126	170								
2600	6,53	18,0	34,6	68,1	102	136	184								
2800	7,04	19,4	37,2	73,3	110	147									
2880	7,24	19,9	38,3	75,4	113	151									
3000	7,54	20,7	39,9	78,5	118	157									
3600	9,05	24,9	47,9	94,2											

The figures in heavier type are for standard motor speeds. All these power ratings are calculated at constant torque. For speeds below 100 rev/min and intermediate speeds use nominal torque ratings.

PHYSICAL CHARACTERISTICS - FLEXIBLE TYRES

Characteristics	Coupling Size														
	F40	F50	F60	F70	F80	F90	F100	F110	F120	F140	F160	F180	F200	F220	F250
Maximum speed rev/min	4500	4500	4000	3600	3100	3000	2600	2300	2050	1800	1600	1500	1300	1100	1000
Nominal Torque Nm TKN	24	66	127	250	375	500	675	875	1330	2325	3770	6270	9325	11600	14675
Maximum Torque Nm TK MAX	64	160	318	487	759	1096	1517	2137	3547	5642	9339	16455	23508	33125	42740
Torsional Stiffness Nm/°	5	13	26	41	63	91	126	178	296	470	778	1371	1959	2760	3562
Max. parallel misalignment mm	1,1	1,3	1,6	1,9	2,1	2,4	2,6	2,9	3,2	3,7	4,2	4,8	5,3	5,8	6,6
Maximum end float mm	1,3	1,7	2,0	2,3	2,6	3,0	3,3	3,7	4,0	4,6	5,3	6,0	6,6	7,3	8,2
Approximate mass, kg	0,1	0,3	0,5	0,7	1,0	1,1	1,1	1,4	2,3	2,6	3,4	7,7	8,0	10	15
Alternating Torque Nm @ 10Hz TKW	11	26	53	81	127	183	252	356	591	940	1556	2742	3918	5521	7124
Resonance Factor V	7	7	7	7	7	7	7	7	7	7	7	7	7	7	7
Damping Coefficient	0,9	0,9	0,9	0,9	0,9	0,9	0,9	0,9	0,9	0,9	0,9	0,9	0,9	0,9	0,9

Maximum torque figures should be regarded as short duration overload ratings for use in such circumstances as direct-on-line starting.

All flexible tyres have an angular misalignment capacity up to 4°

FLEXIBLE TYRE CODE NUMBERS

Unless otherwise specified Martin Flexible tyres will be supplied in a natural rubber compound which is suitable for operation in temperatures -50°C to +50°C.

A chloroprene compound is available which is Fire Resistant and Anti-Static (F.R.A.S.) and has greater resistance to heat and oil.

This is suitable for operation in temperatures -15°C to +70°C. For temperatures outside these ranges - consult Martin.

Tyre Part Numbers		
Size	Natural	F.R.A.S.
F40	F40NA	F40FR
F50	F50NA	F50FR
F60	F60NA	F60FR
F70	F70NA	F70FR
F80	F80NA	F80FR
F90	F90NA	F90FR
F100	F100NA	F100FR
F110	F110NA	F110FR
F120	F120NA	F120FR
F140	F140NA	F140FR
F160	F160NA	F160FR
F180	F180NA	F180FR
F200	F200NA	F200FR
F220	F220NA	F220FR
F250	F250NA	F250FR

BACK STOP/SAFETY DOGS

POSITIVE DRIVE APPLICATIONS

In the unlikely event of the failure of the flexible tyre, the drive can be maintained with the interaction of fitted back stop/safety dogs.

Safety dogs are available for coupling sizes F70 to F250 and should be fitted when it is essential to avoid run back, e.g. cranes, hoists, lifts, elevators, inclined conveyors, etc. Consult local Martin distributor for details.

**Whatever Your Need For Couplings
Martin Has Them**

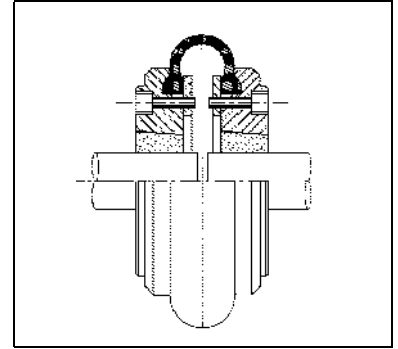
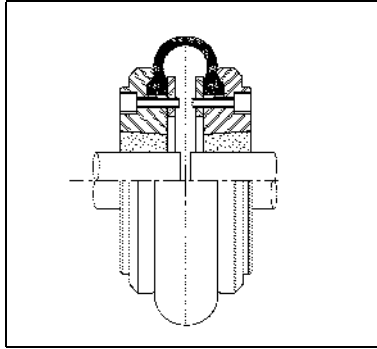
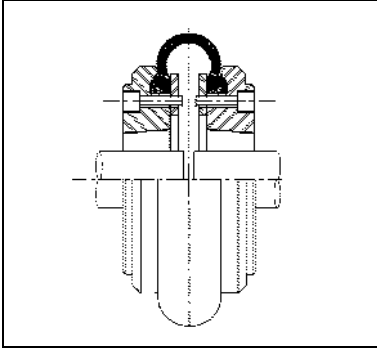

SIZES F40-60

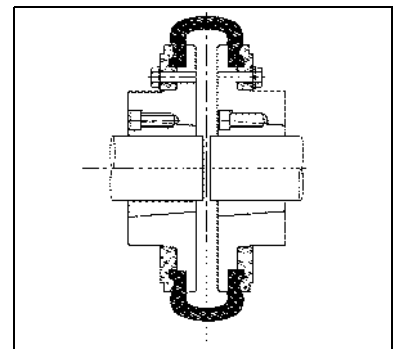
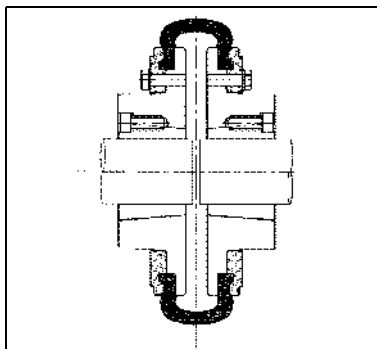
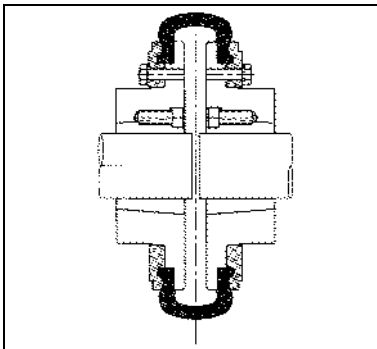

SIZES F70-250

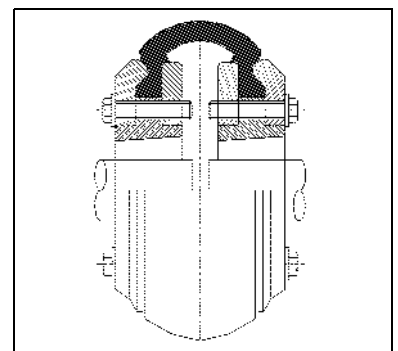
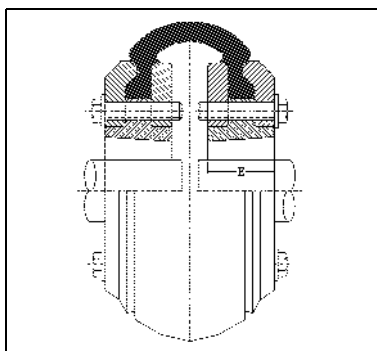
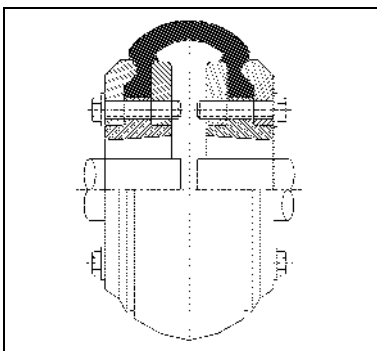

**SIZES F70-120
(Reversible)**

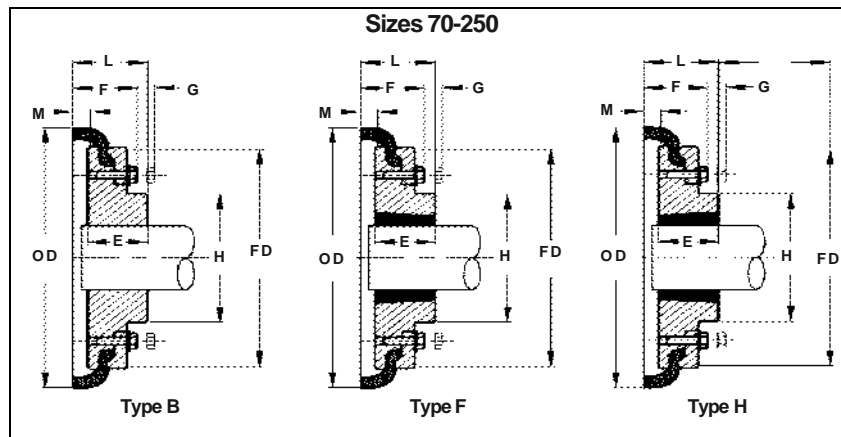
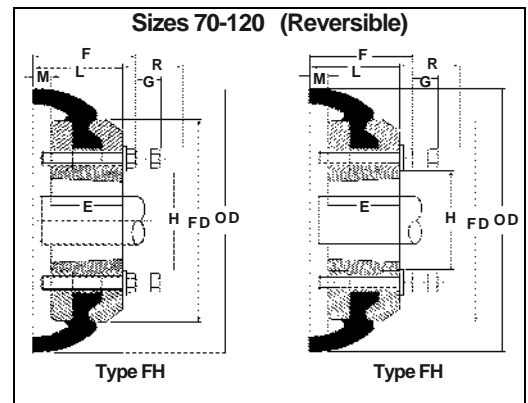
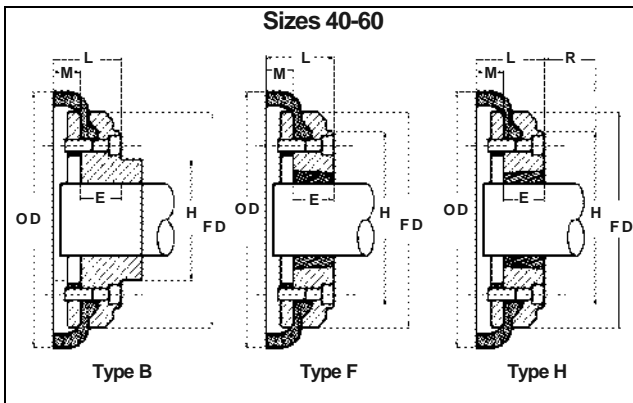

DIMENSIONS OF Martin - FLEX FLANGES/TYPES B, F, H & FH

Part Number	Size	Type	Bush No.	Max. Bore (B) Metric	Types F & H			Type B		Screw over Key	O.D.	FD	H	F	G*	M*	Mass* (kg)	Inertia* (kgm2)
					L	E	R*	L	E									
F40B	F40	B	—	30	—	—	29	33	22	M5	104	82	—	—	—	11	0,8	,0007
F40F	F40	F	1008	25	33	22	29	—	—	—	104	82	—	—	—	11	0,8	4
F40H	F40	H	1008	25	33	22	29	—	—	—	104	82	—	—	—	11	0,8	,0007
F50B	F50	B	—	38	—	—	38	45	32	M5	133	100	79	—	—	12,5	1,2	4
F50F	F50	F	1210	32	37,5	25	38	—	—	—	133	100	79	—	—	12,5	1,2	,0007
F50H	F50	H	1210	32	37,5	25	38	—	—	—	133	100	79	—	—	12,5	1,2	4
F60B	F60	B	—	45	—	—	38	55	38	M6	165	125	70	—	—	16,5	2,0	,0011
F60F	F60	F	1610	42	41,5	25	38	—	—	—	165	125	103	—	—	16,5	2,0	5
F60H	F60	H	1610	42	41,5	25	38	—	—	—	165	125	103	—	—	16,5	2,0	,0011
F70B	F70	B	—	50	—	—	—	47	35	M10	187	142	80	50	13	11,5	3,1	5
F70F	F70	F	2012	50	43,5	32	42	—	—	—	187	142	80	50	13	11,5	3,1	,0011
F70H	F70	H	1610	42	36,5	25	38	—	—	—	187	142	80	50	13	11,5	3,0	5
F70FH	F70	FH	1610	42	37	25	42	—	—	M8	187	142	80	44,25	13	11,5		
F80B	F80	B	—	63	—	—	—	55	42	M10	211	165	98	54	16	12,5	4,9	,0052
F80F	F80	F	2517	60	57,5	45	48	—	—	—	211	165	97	54	16	12,5	4,9	,0052
F80H	F80	H	2012	50	44,5	32	32	—	—	—	211	165	98	54	16	12,5	4,6	,0052
F80FH	F80	FH	2012	50	45,5	32	48	—	—	M8	211	165	98	52,75	16	12,5		
F90B	F90	B	—	75	—	—	—	62,5	49	M12	235	187	112	60	16	13,5	7,1	0,009
F90F	F90	F	2517	60	58,5	45	48	—	—	—	235	187	108	60	16	13,5	7,0	0,009
F90H	F90	H	2517	60	58,5	45	48	—	—	—	235	187	108	60	16	13,5	7,0	0,009
F90FH	F90	FH	2517	60	58,5	45	48	—	—	M10	235	187	112	67,86	16	13,5		
F100B	F100	B	—	80	—	—	—	69,5	56	M12	254	214	125	62	16	13,5	9,9	0,018
F100F	F100	F	3020	75	64,5	51	55	—	—	—	254	214	120	62	16	13,5	9,9	0,018
F100H	F100	H	2517	60	58,5	45	48	—	—	—	254	214	113	62	16	13,5	9,4	0,017
F100FH	F100	FH	2517	60	59,5	45	55	—	—	M10	254	214	125	68,86	16	13,5		

Dimensions in millimeters unless otherwise specified.

* G is the amount by which clamping screws need to be withdrawn to release tyre.

J is the wrench clearance to allow for tightening/loosening the bush on the shaft and the clamping screws on sizes F40, F50 and F60. The use of a shortened wrench will allow this dimension to be reduced.

* M is half the distance between flanges, Shaft ends, although normally located twice M apart, can protect beyond the flanges as shown. In this event allow sufficient space between for end float and misalignment.

Mass and inertia figures are for single flange with mid range bore and included clamping ring, screws and washers and half tyre.

For pilot bore 'B' flange code is listed.

Flanges are also available finish bored with keyway if required.

Bore must be specified on order.

#Note: On sizes F70, 80, 100 and 120 the 'F' direction bush is larger than that in the 'H' direction.

Martin-Flex® Couplings - Dimensions

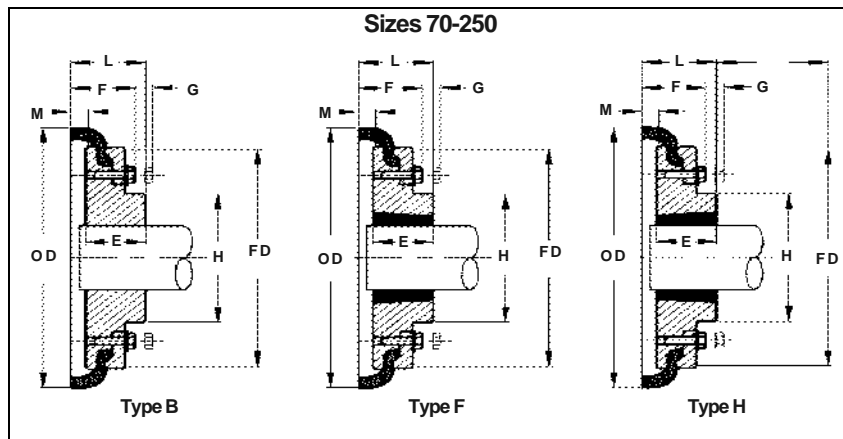
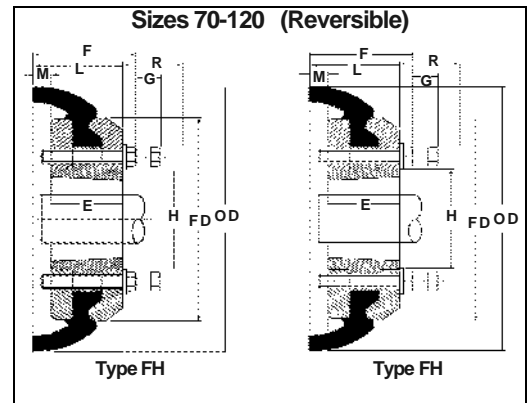
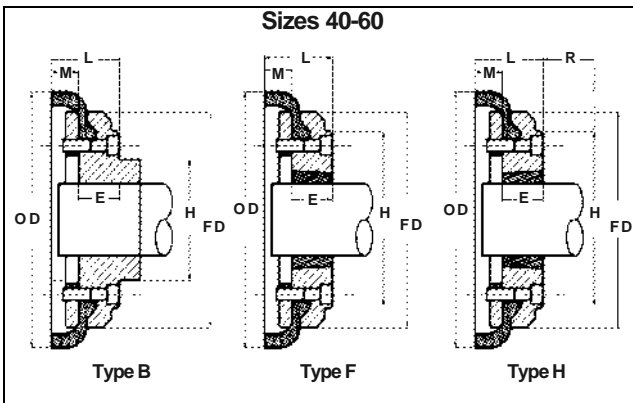

DIMENSIONS OF Martin - FLEX FLANGES TYPES B, F, H & FH

Part Number	Size	Type	Bush No.	Max. Bore (B) Metric	Types F & H			Type B		Screw over Key	O.D.	FD	H	F	G*	M*	Mass* (kg)	Inertia* (kgm2)
					L	E	R*	L	E									
F110B	F110	B	—	90	—	—	—	75,5	63	M12	279	232	128	62	16	12,5	12,5	0,032
F110F	F110	F	3020	75	63,5	51	55	—	—	—	279	232	134	62	16	12,5	11,7	0,031
F110H	F110	H	3020	75	63,5	51	55	—	—	—	279	232	134	62	16	12,5	11,7	0,031
F110FH	F110	FH	3020	75	64,5	51	55	—	—	M10	279	232	134	73,68	16	12,5	—	—
F120B	F120	B	—	100	—	—	—	84,5	70	M16	314	262	143	67	16	14,5	16,9	0,055
F120F	F120	F	3525	100	79,5	65	67	—	—	—	314	262	140	67	16	14,5	16,5	0,055
F120H	F120	H	3020	75	65,5	51	55	—	—	—	314	262	140	67	16	14,5	15,9	0,054
F120FH	F120	FH	3020	75	66,5	51	67	—	—	M12	314	262	140	77,18	16	14,5	—	—
F140B	F140	B	—	125	—	—	—	110,5	94	M20	359	312,5	180	73	17	16	22,2	0,081
F140F	F140	F	3525	100	81	65	67	—	—	—	359	312,5	180	73	17	16	22,3	0,078
F140H	F140	H	3525	100	81	65	67	—	—	—	359	312,5	180	73	17	16	22,3	0,078
F160B	F160	B	—	140	—	—	—	117	102	M20	402	348	197	78	19	15	35,8	0,137
F160F	F160	F	4030	115	91	76	80	—	—	—	402	348	197	78	19	15	32,5	0,137
F160H	F160	H	4030	115	91	76	80	—	—	—	402	348	197	78	19	15	32,5	0,130
F180B	F180	B	—	150	—	—	—	137	114	M20	470	396	205	94	19	23	49,1	0,254
F180F	F180	F	4535	125	112	89	89	—	—	—	470	396	205	94	19	23	42,2	0,255
F180H	F180	H	4535	125	112	89	89	—	—	—	470	396	205	94	19	23	42,2	0,255
F200B	F200	B	—	150	—	—	—	138	114	M20	508	432	205	103	19	24	58,2	0,469
F200F	F200	F	4535	125	113	89	89	—	—	—	508	432	205	103	19	24	53,6	0,380
F200H	F200	H	4535	125	113	89	89	—	—	—	508	432	205	103	19	24	53,6	0,380
F220B	F220	B	—	160	—	—	—	154,5	127	M20	562	472	224	118	20	27,5	79,6	0,871
F220F	F220	F	5040	125	129,5	102	92	—	—	—	562	472	224	118	20	27,5	72,0	0,847
F220H	F220	H	5040	125	129,5	102	92	—	—	—	562	472	224	118	20	27,5	72,0	0,847
F250B	F250	B	—	190	—	—	—	161,5	132	M20	628	532	254	125	25	29,5	104,0	1,301

Dimensions in millimeters unless otherwise specified.

* G is the amount by which clamping screws need to be withdrawn to release tyre.

J is the wrench clearance to allow for tightening/loosening the bush on the shaft and the clamping screws on sizes F40, F50 and F60. The use of a shortened wrench will allow this dimension to be reduced.

* M is half the distance between flanges. Shaft ends, although normally located twice M apart, can protect beyond the flanges as shown. In this event allow sufficient space between for end float and misalignment.

Mass and inertia figures are for single flange with mid range bore and included clamping ring, screws and washers and half tyre.

For pilot bore 'B' flange code is listed.

Flanges are also available finish bored with keyway if required.

Bore must be specified on order.

#Note: On sizes F70, 80, 100 and 120 the 'F' direction bush is larger than that in the 'H' direction.



Martin-Flex® Spacer Couplings

Comprising a Martin-Flex coupling size (F40-F140) complete with a spacer flange designed for use on applications where it is an advantage to be able to move either shaft axially without disturbing the driving or driven machine (e.g. centrifugal pump rotors), Martin-Flex spacer couplings are primarily designed for standard distance between shaft and dimensions 100, 140 and 180mm.

SELECTION

1. Select a suitable size of Martin-Flex coupling using method shown on page C-6. Read down the first column in table below and locate the size of coupling desired.
2. Read across until the required distance between shaft ends can be accommodated.

3. Note the required spacer coupling designation at head of column.
4. Check from the Spacer Coupling Dimensions table below that the selected spacer/coupling combination can accommodate the machine shaft size.

DISTANCE BETWEEN SHAFT ENDS

Size	Distance between Shaft Ends (MM)																			
	SM12		S M16				SM25						SM30				SM35			
	80(100)		100		140		100		140		180		140		180		140		180	
	Min	Max	Min	Max	Min	Max	Min	Max	Min	Max	Min	Max	Min	Max	Min	Max	Min	Max	Min	Max
F40	80	100	100	113	140	150														
F50			100	116	140	156														
F60			100	124	140	164														
F70							100	114	140	154	180	194								
F80							100	117	140	157	180	197								
F90									140	158	180	198								
F100													140	158	180	198				
F110													140	156	180	196				
F120																	140	160	180	200
F140																	140	163	180	203

Note: Alternative distances between shaft ends may be accommodated. Consult Martin.

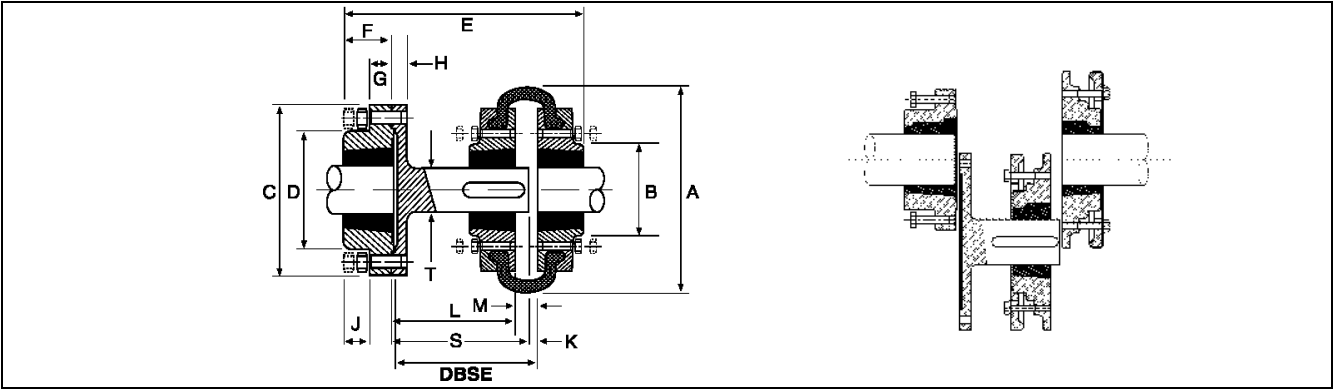

SPACER COUPLING DIMENSIONS

Spacer	Nom DBSE	Martin-Flex	Spacer Bush Size	Max. Bore		Martin-Flex Bush Size	Max. Bore		A	B	C	D	E	F	G	H	J	K	L	M	S	T
				mm	Inch		mm	Inch														
SM12	80	F40	1210	32	1,250	1008	25	1	104	82	118	83	134	25	14	15	14	6	65	22	77	25
SM12	100	F40	1210	32	1,250	1008	25	1	104	82	118	83	140	25	14	15	14	22	77	22	77	25
SM16	100	F40	1615	42	1,625	1008	25	1	104	82	127	80	157	38	18	15	14	9	88	22	94	32
SM16	140	F40	1615	42	1,625	1008	25	1	104	82	127	80	187	38	18	15	14	9	128	22	134	32
SM16	100	F50	1615	42	1,625	1210	32	1,250	133	79	127	80	160	38	18	15	14	9	85	25	94	32
SM16	140	F50	1615	42	1,625	1210	32	1,250	133	79	127	80	200	38	18	15	14	9	125	25	134	32
SM16	100	F60	1615	42	1,625	1610	42	1,625	165	103	127	80	161	38	18	15	14	9	78	33	94	32
SM16	140	F60	1615	42	1,625	1610	42	1,625	165	103	127	80	201	38	18	15	14	9	118	33	134	32
SM25	100	F70	2517	60	2,50	2012	50	2	187	80	178	123	180	45	22	16	14	9	80	23	94	48
SM25	140	F70	2517	60	2,50	2012	50	2	187	80	178	123	220	45	22	16	14	9	120	23	174	48
SM25	180	F70	2517	60	2,50	2012	50	2	187	80	178	123	260	45	22	16	14	9	160	23	174	48
SM25	100	F80	2517	60	2,50	2517	60	2,50	211	95	178	123	193	45	22	16	14	9	78	25	94	48
SM25	140	F80	2517	60	2,50	2517	60	2,50	211	95	178	123	233	45	22	16	14	9	118	25	134	48
SM25	180	F80	2517	60	2,50	2517	60	2,50	211	95	178	123	273	45	22	16	14	9	158	25	174	48
SM25	140	F90	2517	60	2,50	2517	60	2,50	235	108	178	123	233	45	22	16	14	9	116	27	134	48
SM25	180	F90	2517	60	2,50	2517	60	2,50	235	108	178	123	273	45	22	16	14	9	156	27	174	48
SM30	140	F100	3020	75	3	3020	75	3	254	120	216	146	245	51	29	20	17	9	116	27	134	60
SM30	180	F100	3020	75	3	3020	75	3	254	120	216	146	285	51	29	20	17	9	156	27	174	60
SM30	140	F110	3020	75	3	3020	75	3	279	134	216	146	245	51	29	20	17	9	118	25	134	60
SM30	180	F110	3020	75	3	3020	75	3	279	134	216	146	285	51	29	20	17	9	158	25	174	60
SM35	140	F120	3525	100	4	3525	100	4	314	140	248	178	272	63	34	20	17	9	114	29	134	80
SM35	180	F120	3525	100	4	3525	100	4	314	140	248	178	312	63	34	20	17	9	154	29	174	80
SM35	140	F140	3525	100	4	3525	100	4	359	178	248	178	271	63	34	20	17	9	111	27	134	80
SM35	180	F140	3525	100	4	3525	100	4	359	178	248	178	312	63	34	20	17	9	151	27	174	80

Note: Larger sizes of spacer couplings are available. Consult Martin.

* F40 'B' Flange must be used to fit spacer shaft.
 'F' Flange must be used to fit spacer shaft.
 DBSE- distance between shaft ends.

Martin-Flex® Couplings Installation Instructions



NOTE: Satisfactory performance depends on correct installation and maintenance. Under no circumstances should any machine be started unless the coupling and associated machine is completely assembled. All instructions in this manual should therefore be followed accurately.

1. Thoroughly clean all components, paying particular attention to the removal of the protective coating in flange bores and on bushes.
2. Fit flanges to the shafts after placing the external clamp rings on the shafts. (Where Taper flanges are used, see separate fitting instructions supplied with the Taper Bushes.) Locate flanges so that dimension M is obtained (see paragraph 3). Flanges with internal clamping rings should then have the clamping rings fitted, engaging only two or three of the threads of the screws at this time.
3. Bring shafts into line until dimension M is obtained (table 2). If shaft end float is to occur, locate the shafts at mid-position of end float when checking dimension M. Note the shafts ends may project beyond the faces of the flanges if required. In this event, allow sufficient space between shafts for end float and mis-alignment. Flanges should be fitted flush with the end of the shaft when used with Mill-Motor flanges.
4. Check parallel alignment by laying a straight edge across the flanges at several positions around the circumference. Check angular alignment by measuring gap between flanges at several positions around the circumference. It is desirable to align the coupling as accurately as possible, particularly on high speed applications.

5. Open out tyre and fit over coupling flanges ensuring that the tyre beads seat properly on the flanges and/or clamping rings. To ensure proper seating, it may be necessary to strike the outside diameter of the tyre with a small mallet. When seated there should be a gap between the ends of the tyre as shown in Table 1.

TABLE 1

Coupling Size	F40 to F60	F70 to F120	F140 and F160	F180 to F250
Tyre Gap mm	2	3	5	6

6. Tighten clamping ring screws alternately and evenly (half turn at a time) working round each flange until the required screw torque is achieved (table 2).

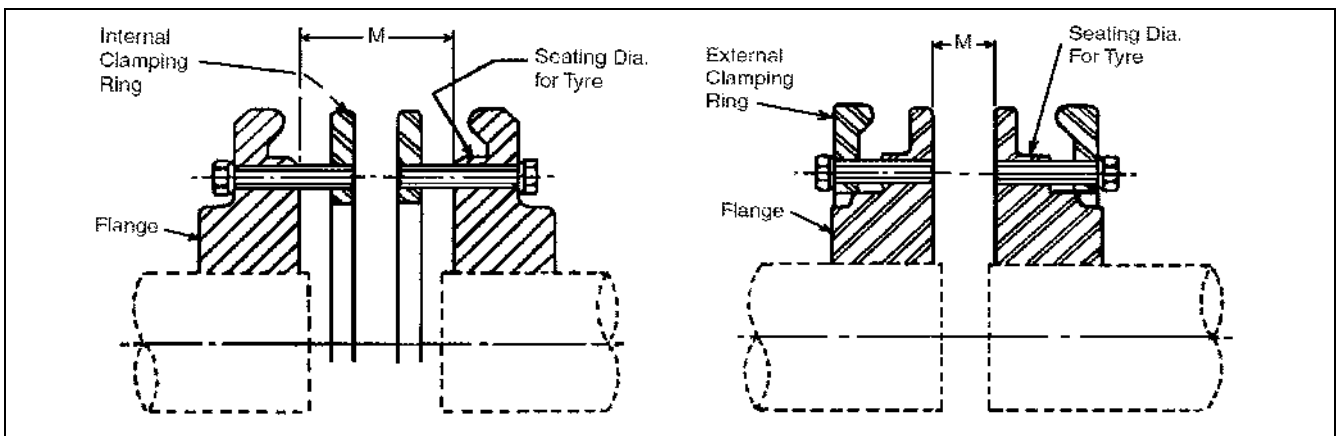

TABLE 2

Coupling Size		F40	F50	F60	F70	F80	F90	F100	F110	F120	F140	F160	F180	F200	F220	F250
M	MM	22	25	33	23	25	27	27	25	29	32	30	46	48	55	59
Screw Size		M6	M6	M6	M8	M8	M10	M10	M10	M12	M12	M16	M16	M16	M20	M20
Clamping Screw Torque	Nm	15	15	15	24	24	40	40	40	50	55	80	105	120	165	165



Martin-Flex® flexible couplings smoothly transmit power while compensating for shaft misalignment to 4°, parallel misalignment to 3,2 and end float to 7,9. The two piece flange design provides quick and easy installation and the elastomeric element absorbs shock and torsional vibration through a wide temperature range.

Quick Selection Procedure

1. Select the proper service factor from Chart 1.
2. Determine **Design Kw** by multiplying the **Service Factor** and the **Drive Kw**.
3. Locate the intercept of **Shaft Speed** and **Design Kw** from Chart 2.
4. Order per coupling: (2) bushings, (2) flange assemblies, (1) flexible tire element.

Chart 1 Service Factors

Application	Factor	Application	Factor	Application	Factor	Application	Factor	Application	Factor
AGITATORS		Pump, Screen Drive, Stacker, Utility Winch	1,5	METAL FORMING MACHINES		Hog.....	2,0	Water.....	1,0
Paddle or Propeller (Vert. or Horiz.), Screw.....	1,0	DYNAMOMETER.....	1,0	Draw Bench Carriage, Main Drive, Extruder, Machine.....	2,0	Roller.....	1,5	SEWAGE DISPOSAL EQUIPMENT.....	1,0
BREWING AND DISTILLING		ELEVATORS		Wire Drawing, Flattening Machine.....	2,0	PUMPS		SHOVEL.....	2,0
Bottling Machinery, Brew Kettle, Cooker (Cont. Duty), Mash Tub.....	1,0	Bucket, Freight.....	2,0	MILLS (Rotary Type)		Centrifugal.....	1,0	SHREDDER.....	1,5
Scale Hopper —		EXCITER	1,0	Ball or Pebble Direct or on LS Shaft Gear Reducer... ..	2,5	Descaling, Gear Type.....	1,5	STEEL INDUSTRY	
Frequent Starting Peaks.....	1,5	FANS		Dryer and Cooler.....	1,5	Oil Well Pumping (not over 150% peak torque).....	2,0	Cold Mills	
CAN FILLING MACHINE	1,0	Centrifugal.....	1,0	on HS Shaft Gear Reducer... ..	2,0	Rotary — other than gear... ..	1,5	Coiler (up or down).....	1,5
CAR DUMPER	1,5	Cooling Tower.....	2,0	Dryer or Cooler.....	1,5	Reciprocating —		Strip, Temper	2,0
CAR PULLER	1,5	Large (Mine, etc.).....	1,5	Rod or Tube Direct or on LS Shaft Gear Reducer... ..	2,5	1 cyl. — single acting	2,5	Hot Mills	
CLARIFIER	1,0	Light.....	1,0	on HS Shaft Gear Reducer... ..	2,5	1 cyl. — double acting.....	2,0	Coiler (up or down), Edger Drive.....	1,5
CLASSIFIER	1,0	Propeller (Indoor).....	1,5	on HS Shaft Gear Reducer... ..	2,0	2 cyl. — single acting	2,0	Feed Roll (Blooming), Roughing Mill Delivery (non-reversing),	
CLAY-WORKING MACHINES		FOOD INDUSTRY		Tumbling Barrel.....	1,5	2 cyl. — double acting.....	1,5	RUBBER INDUSTRY	
Brick Press, Briquette Machine, Clay Working Machine, Pug Mill.....	1,5	Beet Slicer.....	1,5	MIXERS		3 cyl. — or more	1,5	Banbury Mixer.....	2,5
COMPRESSORS		Cereal Cooker.....	1,0	Concrete (Continuous or intermittent), Muller-Simpson type	1,5	RUBBER INDUSTRY		Calender.....	2,0
Lobe, Rotary.....	2,0	Dough Mixer, Meat Grinder.....	1,5	OIL INDUSTRY		Cracker, Mixing Mill, Plasticator.....	2,5	Cracker, Mixing Mill, Plasticator.....	2,5
Reciprocating** —		GENERATORS		Chiller.....	1,0	Refiner, Sheeter, Tire Building Machine.....	2,0	Tire and Tube Press Opener (Based on Peak Torque) ...	1,0
1 cyl. — single acting	3,5	Even Load.....	1,0	Oil Well Pumping (not over 150% peak torque)	2,0	Washer.....	2,5	Tuber and Strainer.....	1,5
1 cyl. — double acting	3,0	Hoist or Railway Service	1,5	Paraffin Filter Press.....	1,5	Warming Mill.....	2,0	Washing Mill.....	2,0
2 cyl. — single acting	3,0	Welder Load.....	2,0	PAPER MILLS		SCREENS		Air Washing.....	1,0
2 cyl. — double acting.....	2,5	GRIZZLY.....	2,0	Agitator.....	1,0	Air Washing.....	1,0	Coal and Sand (Rotary).....	1,5
3 cyl. or more — single acting	2,5	KILN.....	2,0	Barking Drum.....	2,5	Coal and Sand (Rotary).....	1,5	Vibrating.....	2,5
3 cyl. or more — double acting.....	2,0	LAUNDRY MACHINES		Beater and Pulper.....	1,5	TEXTILE MILLS			
CONVEYORS		Tumbler, Washer.....	2,0	Bleacher.....	1,0	Batcher.....	1,0	Calender, Card Machine, Dry Can.....	1,5
Apron, Assembly, Belt, Chain, Flight, Oven.....	1,0	LINE SHAFTS		Calender.....	2,0	Dyeing Machinery.....	1,0	Dyeing Machinery.....	1,0
Reciprocating.....	2,5	Driving Processing Machinery.....	1,0	Chipper.....	3,0	Loom.....	1,5	Mangel, Napper, Soaper	1,0
Screw.....	1,0	Light.....	1,0	Couch, Cylinder, Dryer.....	1,5	Mangel, Napper, Soaper	1,0	Spinner, Tenter Frame	1,5
CRANES AND HOISTS		LUMBER INDUSTRY		Felt Stretcher.....	1,0	Spinner, Tenter Frame	1,5	WINDLASS.....	1,5
Main Hoist — Medium Duty.....	1,5	Band Resaw, Circular Resaw.....	1,5	Fourdrinier.....	1,5	WINDLASS.....	1,5	WOODWORKING MACHINES ..	1,0
Main Hoist — Heavy Duty.....	2,0	Edger, Head Rig, Hog, Log Haul	2,0	Jordan.....	2,0				
Skip Hoist, Travel Motion, Trolley Motion, Slope.....	1,5	Planer.....	1,5	Press.....	2,0				
CRUSHERS		Rolls Non-Reversing	1,5	Pulp Grinder.....	2,0				
Cane.....	2,0	Rolls Reversing.....	2,0	Stock Chest.....	1,5				
Gyratory.....	2,5	Sawdust Conveyor.....	1,0	Stock Pump.....	2,0				
DREDGES		Slab Conveyor, Sorting Table.....	1,5	Reciprocating.....	2,0				
Cable Reel, Conveyor.....	1,5	MACHINE TOOLS		Rotary.....	1,5				
Cutter Head Drive, Jog Drive.....	2,5	Auxiliary.....	1,0	Suction Roll.....	2,0				
		Main Drive, Notching Press, Planer (Reversing), Plate Planer, Punch Press.....	1,5	Winder.....	1,5				
		Traverse.....	1,0	PARAFFIN FILTER PRESS	1,5				
				PRINTING PRESS	1,5				
				PROPELLER (Marine)	1,5				
				PULVERIZERS					
				Hammermill — Light Duty... ..	1,5				
				Hammermill — Heavy Duty... ..	2,0				

The service factors listed are intended only as a general guide for smooth power sources such as electric motors and steam turbines. Add 0,5 to factor for somewhat rougher power sources such as internal combustion engines of four or more cylinders, steam engines and water turbines. Where substantial shock occurs or starting or stopping is frequent as on some "inching" drives and on some reversing drives or where the power source is an internal combustion engine with less than four cylinders — consult factory. Where torsional vibrations occur as in, for example, internal combustion engines or reciprocating compressors or pump applications, check the coupling for possible development of damaging large amplitude vibrations.

** Add 0,5 to factor if without flywheel.

Chart 2 Size Selection

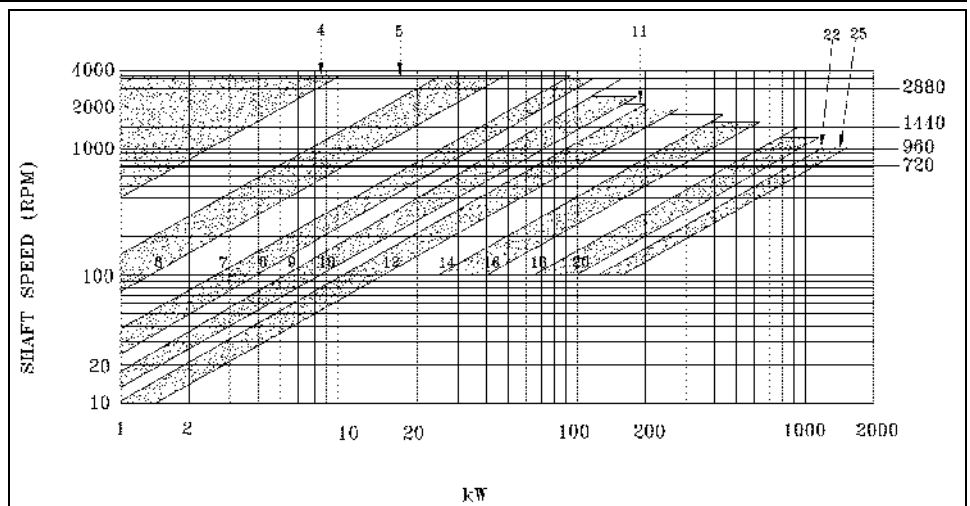

Martin's HRC COUPLINGS

Martin's HRC Couplings offer a range of hub and element selection to meet the demand for a low cost, general purpose spacer type flexible coupling. They allow for incidental misalignment, absorb shock loads and dampen out small amplitude vibrations. They are offered in both Pilot bore, Finished bore, and Taper bushed with both face and hub mount.

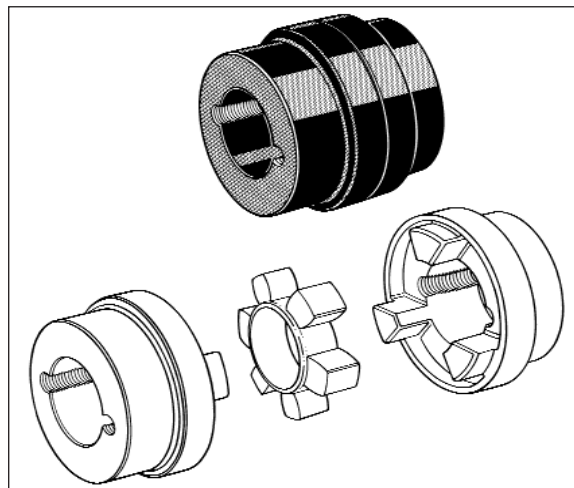
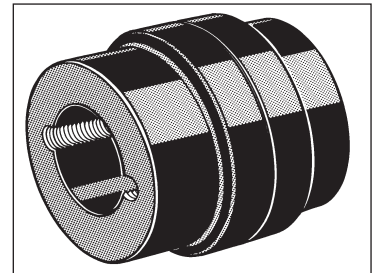
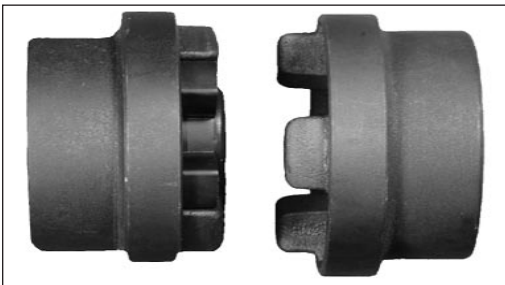

These semi-elastomeric couplings are designed for general purpose applications and permit quick and easy assembly by means of Taper bush. Outside diameters are fully machined to allow alignment by simple straight edge methods. Shaft connection is "fail safe" due to interacting jaw design.

SELECTION

(a) Service Factor

Determine appropriate Service Factor from table below.

(b) Design Power

Multiply running power of driven machinery by the service factor. This gives the design power which is used as a basis for coupling selection.

(c) Coupling Size

Refer to Power Ratings table below and read across from the appropriate speed until a power greater than the design power is found. The size of coupling is given at the head of that column.

(d) Bore Size

From Dimensions table (page C-16) check that the required bores can be accommodated.

EXAMPLE

A shaft coupling is required to transmit 70kW between a 1200 rev/min diesel engine and a hoist running over 16hrs/day. Engine shaft is 70mm and the hoist shaft is 75mm.

(a) Service Factor

The appropriate Service Factor is 2,5.

(b) Design Power

Design power $70 \times 2,5 = 175\text{kW}$.

(c) Coupling Size

Reading across from 1200 rev/min in the speed column of Power Ratings table below, 251kW is the first power to exceed the required 175kW (design power). The size of the coupling at the head of this column is 230.

(d) Bore Size

The Dimensions table (page C-16) shows that both shaft diameters are within the bore range available.

SERVICE FACTORS

SPECIAL CASES For application where substantial shock, vibration and torque fluctuation occur, and for reciprocating machines e.g. internal combustion engines, piston type pumps and compressors, refer to Martin with full machine details for torsional analysis.	Type of Driving Unit					
	Electric Motors Steam Turbines			Internal Combustion Engines Steam Engines Water Turbines		
	Hours per day duty			Hours per day duty		
Driven Machine Class	8 and under	over 8 to 16 inclusive	over 16	8 and under	over 8 to 16 inclusive	over 16
UNIFORM Agitators, Brewing machinery, Centrifugal blowers, Centrifugal compressors+, Conveyors, Centrifugal fans and pumps, Generators, Sewage disposal equipment.	1,00	1,12	1,25	1,25	1,40	1,60
MODERATE SHOCK* Clay working machinery, crane hoists, Laundry machinery, Wood working machinery, Machine tools, Rotary mills, Paper mill machinery, Textile machinery, Non-uniformly loaded centrifugal pumps.	1,60	1,80	2,00	2,00	2,24	2,50
HEAVY SHOCK* Reciprocating conveyors, Crushers, Shakers, Metal mills, Rubber machinery (Banbury mixers and mills), Reciprocating compressors, Welding sets.	2,50	2,80	3,12	3,12	3,55	4,00

*It is recommended that keys (with top clearance if in Taper bushes) are fitted for applications where load fluctuation is expected.

+ For Centrifugal Compressors multiply Service Factor by an additional 1,15.

POWER RATINGS (Kw)

Speed rev/min	Coupling Size							
	70	90	110	130	150	180	230	280
100	0,33	0,84	1,68	3,30	6,28	9,95	20,90	33,00
200	0,66	1,68	3,35	6,60	12,60	19,90	41,90	65,00
400	1,32	3,35	6,70	13,20	25,10	39,80	83,80	132,00
600	1,98	5,03	10,10	19,80	37,70	59,70	126,00	198,00
720	2,37	6,03	12,10	23,80	45,20	71,60	151,00	238,00
800	2,65	6,70	13,40	26,40	50,30	79,60	168,00	264,00
960	3,17	8,04	16,10	31,70	60,30	95,50	201,00	317,00
1200	3,96	10,10	20,10	39,60	75,40	119,00	251,00	396,00
1440	4,75	12,10	24,10	47,50	90,50	143,00	302,00	475,00
1600	5,28	13,40	26,80	52,80	101,00	159,00	335,00	528,00
1800	5,94	15,10	30,20	59,40	113,00	179,00	377,00	594,00
2000	6,60	16,80	33,50	66,00	126,00	199,00	419,00	660,00
2200	7,26	18,40	36,90	72,60	138,00	219,00	461,00	726,00
2400	7,92	20,10	40,20	79,20	151,00	239,00	503,00	
2600	8,58	21,80	43,60	85,80	163,00	259,00	545,00	
2880	9,50	24,10	48,30	95,00	181,00	286,00		
3000	9,90	25,10	50,30	99,00	188,00	298,00		
3600	11,90	30,10	60,30	118,00	226,00			
Nominal Torque (Nm)	31,50	80,00	160,00	315,00	600,00	950,00	2000,00	3150,00
Max Torque (Nm)	72,00	180,00	360,00	720,00	1500,00	2350,00	5000,00	7200,00

Fire Resistant/Anti-Static (F.R.A.S.) inserts are available to special order.

For speeds below 100 rev/min and intermediate speeds use nominal torque ratings.

*Maximum coupling speeds are calculated using an allowable peripheral speed for the hub material. For selection of smaller sizes with speeds in excess of 3600 rev/min - Consult Martin.

HRC Couplings

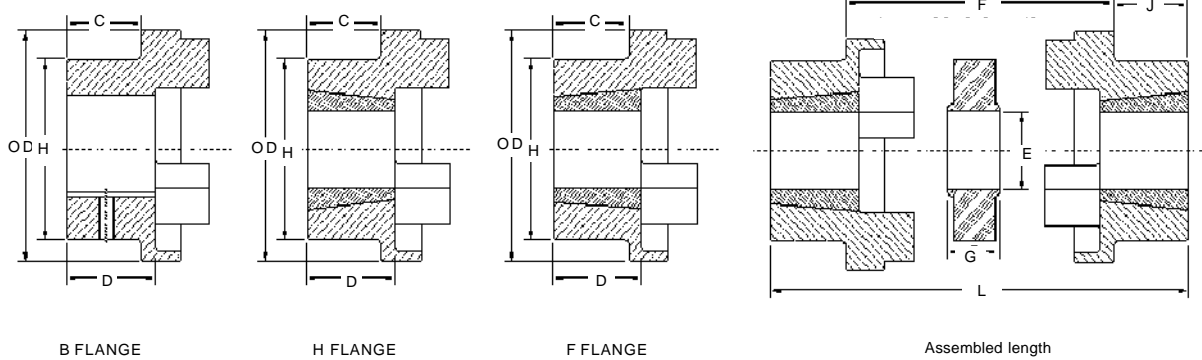

PHYSICAL DIMENSIONS AND CHARACTERISTICS

Size	Common Dimensions					Bush size	Type F&H					Type B				
	OD	H	E	F+	G		Max. Bore		C	D	J+	Bore Dia.		Screw over key	C	D
							MM	Inches				Max.	Pilot H9			
70	69,0	60,0	31,0	25,0	18,0	1008	25	1,000	20,0	23,5	29,0	32	10	M 6	20,0	25,8
90	85,0	70,0	32,0	30,5	22,5	1108	28	1,125	19,5	23,5	29,0	38	10	M 6	26,0	30,0
110	112,0	100,0	45,0	45,0	29,0	1610	42	1,625	18,5	26,5	38,0	55	10	M10	37,0	45,3
130	130,0	105,0	50,0	54,0	36,0	1610	42	1,625	18,0	26,5	38,0	60	20	M10	39,0	47,5
150	150,0	115,0	62,0	61,0	40,0	2012	50	2,000	23,5	33,5	42,0	70	28	M10	46,0	60,0
180	180,0	125,0	77,0	74,0	49,0	2517	60	2,500	34,5	46,5	48,0	80	28	M10	58,0	70,0
230	225,0	155,0	99,0	85,5	59,5	3020	75	3,000	39,5	52,5	55,0	100	45	M12	77,0	90,0
280	275,0	206,0	119,0	105,5	74,5	3525	100	4,000	51,0	66,5	67,0	115	55	M16	90,0	105,5

+ 'J' is the wrench clearance required for tightening/loosening the bush on the shaft. A shortened wrench will allow this dimension to be reduced.

+ F, refers to combinations of flanges: FF, FH, HH, FB, HB, BB.

Bore limits H7 unless specified otherwise.

ASSEMBLED

Size	Assembled Length (L*) Comprising Flange Types			Mass (kg)	Inertia Mr2 (kgm2)	Dynamic Stiffness (Nm)	Maximum Misalignment		Nominal Torque (Nm)
	FF,FH,HH	FB,HB	BB				Parallel	Axial	
70	65,0	65,0	65,0	1,00	0,00085	—	0,3	+0,2	70
90	69,5	76,0	82,5	1,17	0,00115	—	0,3	+0,5	90
110	82,0	100,5	119,0	5,00	0,00400	65	0,3	+0,6	110
130	89,0	110,0	131,0	5,46	0,00780	130	0,4	+0,8	130
150	107,0	129,5	152,0	7,11	0,01810	175	0,4	+0,9	150
180	142,0	165,5	189,0	16,60	0,04340	229	0,4	+1,1	180
230	164,5	202,0	239,5	26,00	0,12068	587	0,5	+1,3	230
280	207,5	246,5	285,5	50,00	0,44653	1025	0,5	+1,7	280

Dimensions in millimeters unless otherwise specified.

All HRC Elements have an angular misalignment capacity of up to 1°.

Mass is for an FF, FH or HH coupling with mid range Taper Bushes.

ORDERING CODES

Size	Type F	Type H	Type B Unbored	Standard Element Tempr. -40°C/+100°C	FRAS Element Tempr. -20°C/+80°C
70	HRC70F	HRC70H	HRC70B	HRC70NA	HRC70FR
90	HRC90F	HRC90H	HRC90B	HRC90NA	HRC90FR
110	HRC110F	HRC110H	HRC110B	HRC110NA	HRC110FR
130	HRC130F	HRC130H	HRC130B	HRC130NA	HRC130FR
150	HRC150F	HRC150H	HRC150B	HRC150NA	HRC150FR
180	HRC180F	HRC180H	HRC180B	HRC180NA	HRC180FR
230	HRC230F	HRC230H	HRC230B	HRC230NA	HRC230FR
280	HRC280F	HRC280H	HRC280B	HRC280NA	HRC280FR

Note: For details of HRC couplings suitable for application to drives involving SAE engine flywheels, consult Martin.

Type B flanges can be supplied finished bored, with keyway if required.

Martin Offers The Martin Universal — Completely Interchangeable

- No Lubrication
- Easy Installation
- No Metal to Metal Contact
- Resistant to oil, dirt, sand, moisture, grease
- Easy inspection of load carrying Spider
- Flexibility of angular or parallel misalignment of shafts by Bruna-N Spider member permits smooth “Power Transmission”



ML -Type

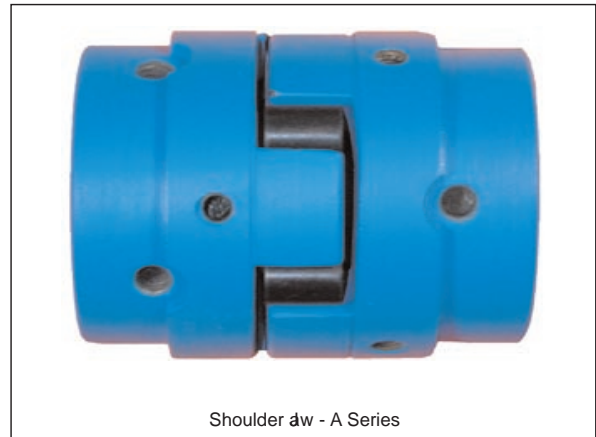

Shoulder Jaw - A Series



ML -Type
(Assembly)

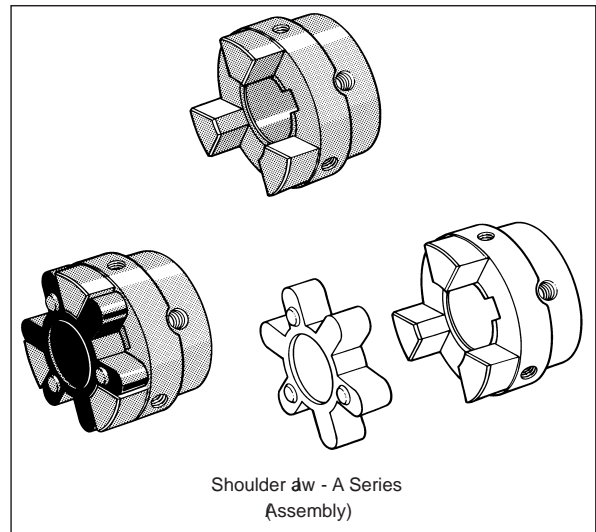

Shoulder Jaw - A Series
(Assembly)

Flexible Jaw Couplings



Martin Jaw Couplings offer a range of hub and element variants to meet the demand for low cost, general purpose and spacer type flexible couplings. They cater for incidental misalignment, absorb shock loads and damp out small amplitude vibrations.

HUBS & SPACERS

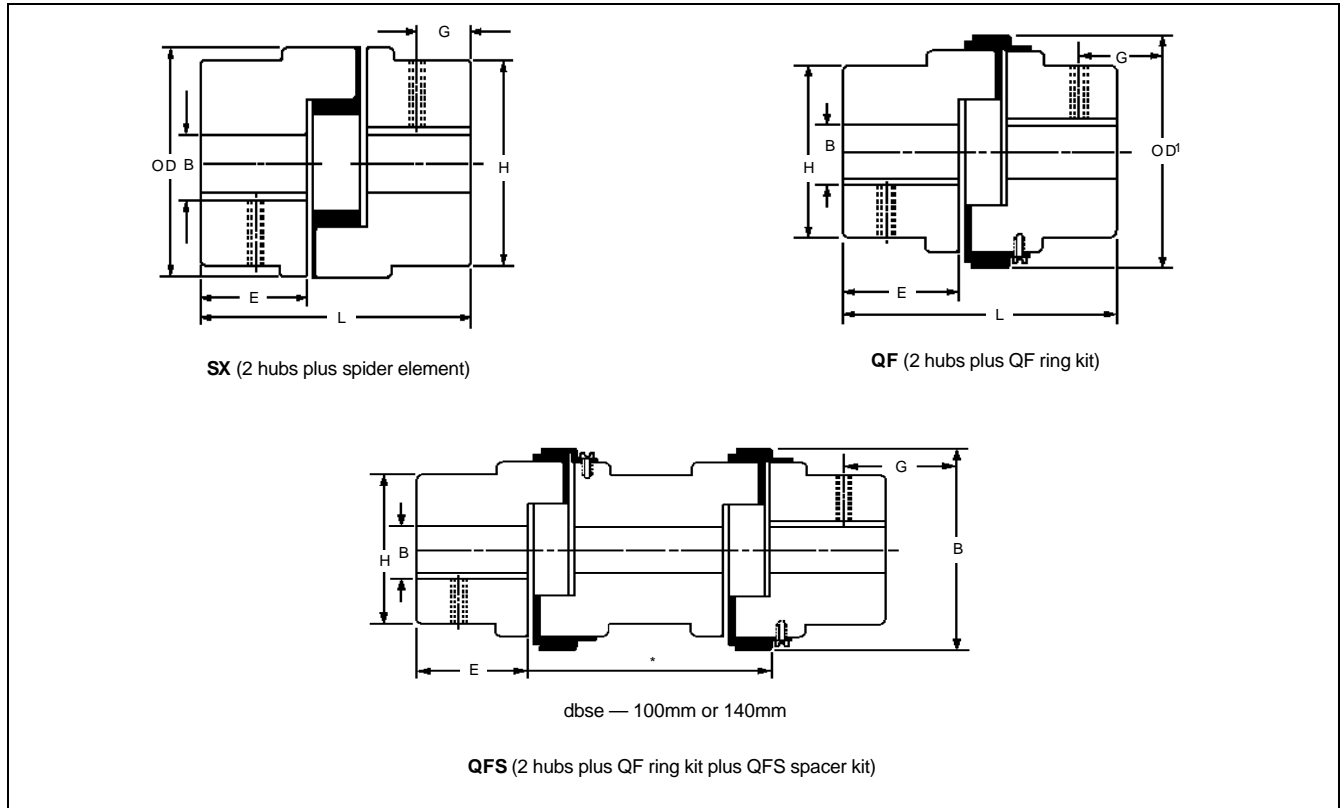

DIMENSIONS: SX, QF AND QFS

Size	B		OD	OD ¹	L	E	H	G	Set Screw	Approx + mass (kg)	Max Speed (rpm)
	Pilot	Max									
035	3,20	9,5	15,9	—	20,6	6,7	15,9	—	—	,06	31000
050	6,35	14	27,5	—	44	16	27,5	6,5	M6	,10	18000
070	6,35	19	35	—	51	19	35	9,5	M6	,25	14000
075	6,35	24	44,5	—	54	21	44,5	9,0	M6	,45	11000
090	6,35	24	54	—	54	21	54	8,7	M6	2,00	9000
095	11,11	28	54	64	64	25	54	11,0	M8	,86	9000
100	12,70	35	65	77	89	35	65	11,0	M8	1,66	7000
110	15,87	42	84	97	108	43	84	19,0	M10	3,70	5000
150	15,87	48	96	112	115	45	96	22,0	M10	5,04	4000
190	19,05	55	115	130	133	54	102	22,0	M12	7,32	3600
225	19,05	60	127	143	153	64	108	29,0	M12	8,40	3600

Dimensions in millimeters unless otherwise specified. Hub material is high grade cast iron. Spacer material is aluminum. dbse = distance between shaft ends
 + Mass of complete SX or QF type with pilot bore hubs
 Bored or bored and keywayed hubs can be supplied.

*Bored or bored and keywayed hubs can be supplied in SX and QF styles.
 Bores are to ISO 268 H7 tolerance (BS 4500 ; 1969). Keyways are to BS 4235 for metric bores and to BS 46 Pt 1 : 1958 for Imperial bores.

Jaw Coupling Selection Procedure

- A. Determine Service Factor by Matching Driven Unit with Prime Mover in Service Factor Guide.
- B. Multiply Service Factor by Driven Unit or Motor Kw. to Obtain Adjusted Kw.
- C. Select Flexible Coupling with Kw. Capacity Equal to or Greater than Adjusted Kw.

Service Factor Guide	Prime Mover		
	Electric Motor or Steam Turbine	Gasoline or Diesel Engine, 6 or More Cyl.	Gasoline or Diesel Engine, Less Than 6 Cyl.
Driven Unit (Machinery)			
Light: Uniform or steady load never exceeding horsepower rating, infrequent starting. Agitators, Blowers, Conveyors, Evaporators, Fans, Generators, Centrifugal Pumps, Stokers	1,0	1,5	2,0
Moderate: Heavy inertia, moderate shock, frequent starting; peak loads do not exceed 125 per cent average horsepower. Uneven load. Beaters, Rotary Pumps and Compressors, Cranes, Elevators, Mine and Propeller Fans, Generators, Pulp Grinders, Hoists, Kilns, Machine Tools, Mixers, Gear Pumps, Woodworking Machines	1,5	2,0	2,5
Heavy: Heavy shock conditions or frequent reversing. Peak loads do not exceed 150 per cent average horsepower. Uneven load. Reciprocating Pumps and Compressors, Crushers, Freight and Passenger Elevators, Mills (Hammer, Ball, Rolling, Turf, Flour), Vibrating Screens, Winches, Wire Drawing Machines, Punches, Shears	2,0	2,5	3,0

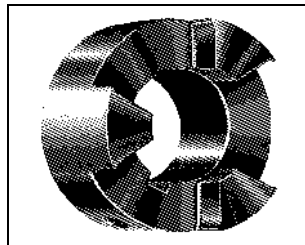
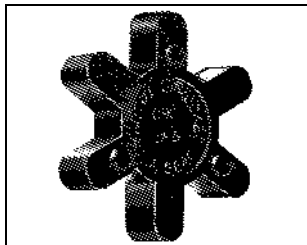
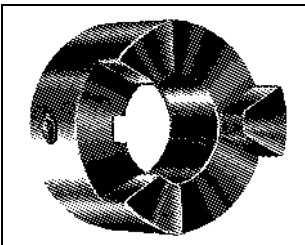

Bore Tolerances: = H7

Martin ML (Universal Series) — Torque and Kilowatt Ratings

Catalog Number	Torque Rating Nm.		Bruna-N Kilowatt Capacity at Various RPM									Max. Bore	Weight (kg) (Each)
	Bruna-N	Hytrel®*	100	300	720	960	1200	1440	1800	2880	3600		
035 *	0,46	—	,005	,01	,04	,05	,05	,07	0,1	,14	0,18	9,5	,03
050	3,51	10,7	,037	,11	,26	,35	,45	,53	,7	1,05	1,3	15,9	,06
070	5,77	14,2	,06	,16	,43	,58	,63	,87	,9	1,73	2,17	19,1	,11
075	11,94	27,3	,125	,29	,90	1,20	1,16	1,80	1,7	3,61	4,51	22,2	,20
090	19,6	47,5	,201	,49	1,44	1,93	1,97	2,89	3,0	5,78	7,22	28,6	,31
095	25,8	64,1	,27	,67	1,95	2,59	2,7	3,89	4,0	7,78	9,73	28,6	,38
100	46,4	141,0	,58	1,5	4,18	5,58	5,9	8,36	8,9	16,73	20,91	34,9	,67
110	89,0	256,2	1,10	2,7	7,94	10,59	10,7	15,88	16,1	31,77	39,71	41,3	1,45
150	141,0	405,7	1,50	4,3	11,23	14,98	17,0	22,35	25,5	44,70	51,0	47,6	2,04
190	190,0	512,5	2,01	5,4	15,07	20,09	21,5	30,14	32,2	60,28	64,4	54,0	3,74
225	265,0	768,7	2,76	8,1	21,09	28,13	32,2	41,40	48,3	82,80	96,6	66,7	5,44

NOTE: Above Kw. capacities are for Bruna-N rubber spider and service factor of one. When Hytrel spider is used multiply capacities by three.

* Available From U.S.A. Only.

Stock Jaw Couplings

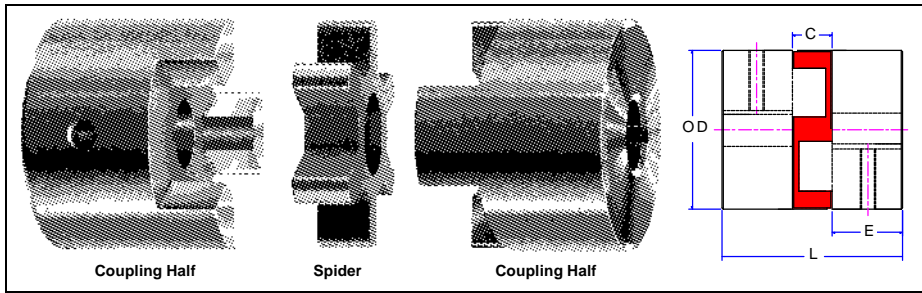

Spiders — Bruna-N (Rubber) and Hytrel

Catalog Number		Accommodates Coupling	Net Weight (Kg.)	
Bruna-N	Hytrel*		Bruna-N	Hytrel
SRL035	SHL035	ML035	,004	,004
SRL050	SHL050	M 050 — MS 050	,006	,006
SRL070	SHL070	ML070 — MS 070	,008	,008
SRL075	SHL075	ML075 — MS 075	,01	,01
SRL090	SHL090	ML or MS090-095	,02	,02
SRL099	SHL099	ML or MS099-100	,03	,03
SRL110	SHL110	ML110 — MS110	,06	,06
SRL150	SHL150	M150 — MS150	,10	,10
SRL190	SHL190	ML190 — MS190	,12	,12
SRL225	SHL225	ML225 — MS225	,19	,19

Urethane spiders available. Please consult factory.
*Available From U.S.A Only.

Spiders — Urethane† and Bronze *

Catalog Number		Accommodates Coupling	Net Weight (Kg.)	
Urethane	Bronze H		Urethane	Bronze
SUL035		ML 035	,004	
SUL050		ML050 — MS050	,006	
SUL070		ML070 — MS070	,008	
SUL075		ML075 — MS075	,01	
SUL090		ML or MS 090-095	,02	
SUL099		ML or MS 099-100	,03	
SUL110		ML110 — MS110	,06	
SUL150		ML150 — MS150	,10	
SUL190		ML190 — MS190	,12	
SUL225		ML225 — MS225	,19	

★ Bronze spiders available as Made to Order.

Coupling Selection Chart for 50 Hz Nema Motor Frames Based on Bruna-N (Rubber) Spider ★†

Shaft Diameter	ISO Standards	Coupling Size	Max. Kilowatt Rating @ RPM					
			1140		1725		3450	
			MS	ML	MS	ML	MS	ML
9,5	42	050	0,4	0,4	0,7	0,6	1,5	1,1
12,7	48	050	0,4	0,4	0,7	0,6	1,5	1,1
15,9	56,56 H	050	0,4	0,4	0,7	0,6	1,5	1,1
19,1	66	070	0,7	0,6	1,1	0,7	2,2	1,5
22,2	56HZ, 143T, 145T	075	1,5	0,7	2,2	1,5	5,6	2,2
	182, 184	090	2,2	1,5	3,7	2,2	7,5	5,6
28,6	182T, 184T, 213	095	2,2	2,2	3,7	3,7	7,5	7,5
	215	099	5,6	3,7	7,5	5,6	18,6	11,2
34,9	213T, 215T, 245U, 256U	100	5,6	5,6	7,5	7,5	18,6	14,9
41,3	254T, 256T, 248U, 286U	110	11,2	7,5	18,6	14,9	37,3	29,8
47,6	284T, 286T, 324U, 326U, 326TS	150	22,4	14,9	29,8	22,4	55,9	44,7
54,0	324T, 326T, 364U, 365U	190	29,8	18,6	44,7	29,8	93,2	55,9
60,3	364T, 365T 225	50	29,8	55,9	44,7	111,9	74,6	

NOTE: Coupling Sizes are based on the rated torque, max. bore and a have a service factor of 1,0. Dimensions in millimeters unless otherwise specified.

* When Using Hytrel or Bronze spider multiply above Kw ratings by 3.

† When using Urethane spider multiply above Kw ratings by 1,5.

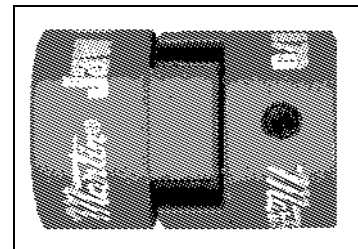

Metric & Imperial
Bore Sizes Available

ML Type Couplings

ML Type couplings range in size from 035 to 225. The coupling design provides for a collar to be attached to our hub shielding the snap wrap spider. Ordering requires selecting Item (UPC) numbers for one standard ML type hub (without collar attachment), one standard snap wrap center insert and one collar with screws.

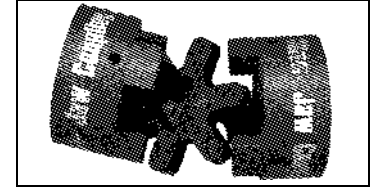
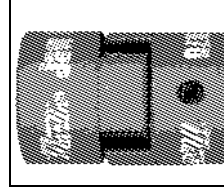

Standard Bore and Keyway Chart

Bore mm	Keyway mm	035	050	070	075	090	095	099	100	110	150	190	225
4	No KW	X	—	—	—	—	—	—	—	—	—	—	—
5	No KW	X	X	—	—	—	—	—	—	—	—	—	—
6	No KW	X	X	—	—	—	—	—	—	—	—	—	—
7	No KW	X	X	X	—	—	—	—	—	—	—	—	—
8	No KW	X	X	X	—	X	—	—	—	—	—	—	—
9	3 x 1,4	—	X	X	X	—	—	—	—	—	—	—	—
10	No KW	—	X	X	X	—	—	—	—	—	—	—	—
10	3 x 1,4	—	X	X	X	X	—	—	—	—	—	—	—
11	4 x 1,8	—	X	X	X	—	X	—	—	—	—	—	—
12	No KW	—	X	X	—	X	—	—	—	—	—	—	—
12	4 x 1,8	—	X	X	X	X	X	—	X	—	—	—	—
14	No KW	—	X	X	—	X	X	—	—	—	—	—	—
14	5 x 2,3	—	X	X	X	X	X	X	X	—	—	—	—
15	No KW	—	X	—	X	—	X	X	X	—	—	—	—
15	5 x 2,3	—	X	X	X	X	X	X	X	—	—	—	—
16	5 x 2,3	—	X	X	X	X	X	X	X	X	X	—	—
17	5 x 2,3	—	—	X	X	—	X	—	X	X	X	—	—
18	6 x 2,8	—	—	X	X	X	X	X	X	X	—	—	—
19	No KW	—	—	—	—	X	—	—	—	X	—	—	—
19	6 x 2,8	—	—	X	X	X	X	X	X	X	X	X	—
20	6 x 2,8	—	—	—	X	X	X	X	X	X	X	X	—
22	6 x 2,8	—	—	—	X	X	X	X	X	X	X	—	—
24	8 x 3,3	—	—	—	—	X	X	X	X	X	X	X	—
25	8 x 3,3	—	—	—	—	X	X	X	X	X	X	X	—
28	No KW	—	—	—	—	—	—	—	—	—	X	X	—
28	8 x 3,3	—	—	—	—	—	X	X	X	X	X	X	—
30	8 x 3,3	—	—	—	—	—	—	X	X	X	X	X	X
32	No KW	—	—	—	—	—	—	—	—	—	X	X	X
32	10 x 3,3	—	—	—	—	—	—	—	X	X	X	X	X
35	No KW	—	—	—	—	—	—	—	—	—	X	X	X
35	10 x 3,3	—	—	—	—	—	—	—	X	X	X	X	X
38	10 x 3,3	—	—	—	—	—	—	—	—	X	X	X	X
40	12 x 3,3	—	—	—	—	—	—	—	—	X	X	X	X
42	12 x 3,3	—	—	—	—	—	—	—	—	X	X	X	X
45	14 x 3,8	—	—	—	—	—	—	—	—	—	X	X	X
48	No KW	—	—	—	—	—	—	—	—	—	X	—	—
48	14 x 3,8	—	—	—	—	—	—	—	—	—	X	X	X
50	No KW	—	—	—	—	—	—	—	—	—	—	X	X
50	14 x 3,8	—	—	—	—	—	—	—	—	—	—	X	X
55	No KW	—	—	—	—	—	—	—	—	—	—	X	X
55	16 x 4,3	—	—	—	—	—	—	—	—	—	—	X	X
60	No KW	—	—	—	—	—	—	—	—	—	—	—	X
60	18 x 4,4	—	—	—	—	—	—	—	—	—	—	—	X
65	No KW	—	—	—	—	—	—	—	—	—	—	—	—
65	18 x 4,4	—	—	—	—	—	—	—	—	—	—	—	X
70	20 x 4,9	—	—	—	—	—	—	—	—	—	—	—	—

Jaw Couplings



ELEMENTS

Type	Temperature Range (°C)	Max Misalignment		Power Factor
		Ang°	Par. (MM)	
Nitrile (Spider)	-40 to 100	1	0,38	1
Nitrile (QF)	-40 to 100	1	0,38	1
Urethane	-35 to 70	1	0,38	1,5
Hytrel®	-50 to 120	.50	0,38	3*

4th digit = Alpha character for coupling size

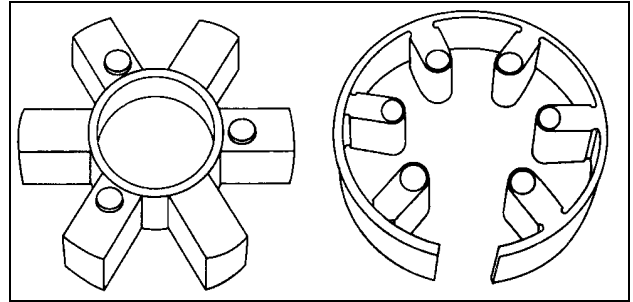

SELECTION

- Find Service Factor for application from table right.
- Multiply normal running power by Service Factor.
- Select a standard nitrile element coupling size from Power Ratings table below by reading across from the appropriate speed until a power equal to or greater than the design power is found. Coupling size is at the head of the column.
- For alternative elements multiply the design power from step (b) by the Element Power Factor in table above and repeat step (c) with the new design power.
- For speeds other than those listed use the nominal torque ratings from the Power Ratings table below.

$$\text{Required Torque (Nm)} = \frac{\text{Design power (Kw)} \times 9555}{\text{rev/min}}$$
- Check for the hub Dimensions tables that bore capacity is adequate for the coupled shafts.
- Orders for complete couplings should give part numbers for hubs, elements and spacers separately.

SERVICE FACTORS

Driven Load	Prime Mover
	Electric Motor
Uniform Load	1,0
Moderate Shock	1,5
Heavy Shock	2,0

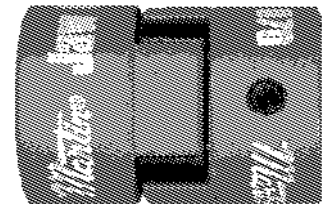

SPACERS AND QF RETAINING RINGS-CODES

All codes first 4 digits: 968-

4th digit: Alpha character for coupling size

5/6th digits: Spacer kit = 33; Retaining ring kit = 99

7/8th digits: Retaining ring kit = 00; Spacer kit 100mm = 10; Spacer kit 140mm = 14

POWER RATINGS (kW) — NITRILE ELEMENTS

Speed (rev/min)	Coupling Size									
	050	070	075	090	095	100	110	150	190	225
100	0,037	0,06	0,12	0,20	0,27	0,58	1,10	1,56	2,09	2,93
720	0,26	0,43	0,90	1,44	1,95	4,18	7,94	11,23	15,07	21,09
960	0,35	0,58	1,20	1,93	2,59	5,58	10,59	14,98	20,09	28,13
1440	0,53	0,87	1,80	2,89	3,89	8,36	15,88	22,46	30,14	42,20
2880	1,05	1,73	3,61	5,78	7,78	16,73	31,77	44,93	60,28	84,40
3600	1,32	2,17	4,51	7,22	9,73	20,91	39,71	56,16	75,35	105,5
Nominal Torque (Nm)	3,51	5,77	11,9	19,2	25,8	55,4	105	150	200	280

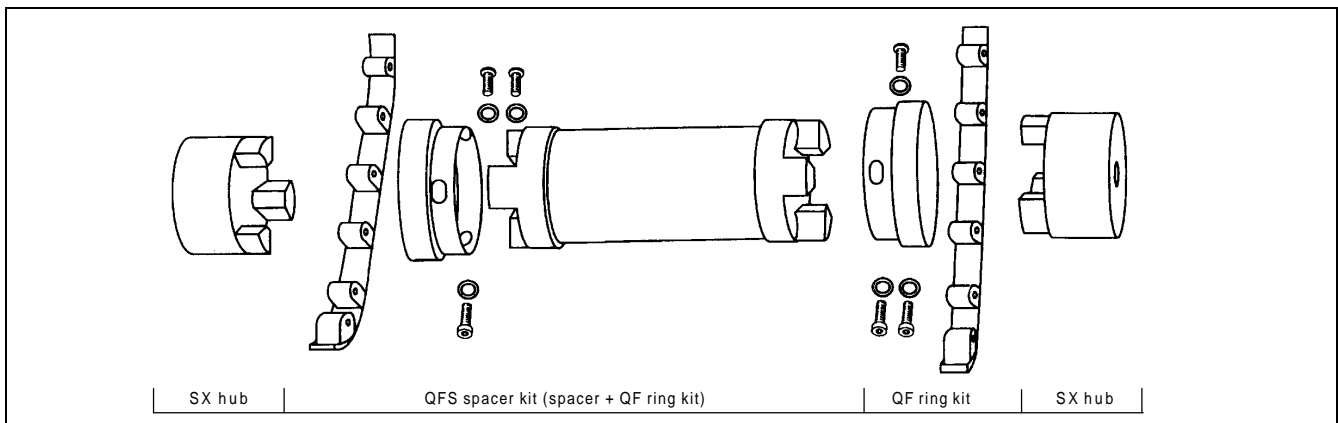

Taper Bush Rigid Couplings provide a convenient method of rigidly connecting ends of shafts. Taper Bushes permit easier and quicker fixing to the shafts with the firmness of a shrunk-on-fit.

These couplings have a male and female flange fully machined. The male flange can have the bush fitted from the Hub side **H** or from the Flange side **F**, the female flange always has the

bush fitting **F**. This gives two possible coupling assemblies horizontal shafts, the most convenient assembly should be chosen. **When connecting vertical shafts use assembly FF only.**

SELECTION

For all applications using standard mild steel shafting it is sufficiently accurate to select the coupling by consideration of bore size alone.

For all other applications consult *Martin*.

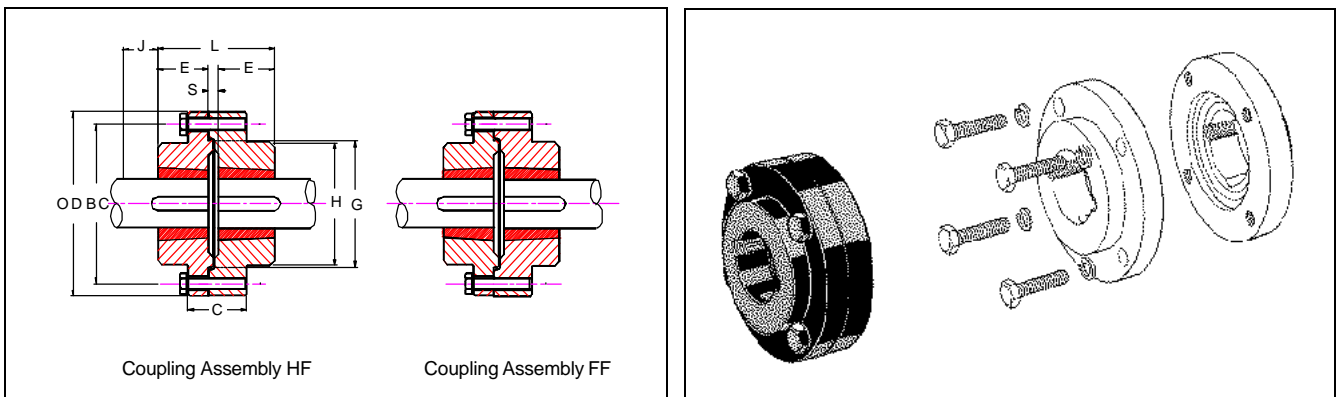

DIMENSIONS

Size	Bush No.	Max. Bore		OD	C	H	E	G nominal	BC nominal	S+	J*	L	Mass++ (kg)
		Metric											
RM12	1210	32		118	35	83	25	76	102	7	38	57	3,5
RM16	1615	42		127	43	80	38	89	105	7	38	83	4,5
RM25	2517	60		178	51	123	45	127	149	7	48	97	11
RM30	3020	75		216	65	146	51	152	181	7	54	109	20
RM35	3525	100		248	75	178	65	178	213	7	67	137	34
RM40	4030	110		298	76	210	76	216	257	7	79	159	59
RM45	4535	125		330	86	230	89	241	286	7	89	185	80
RM50	5040	125		362	92	266	102	267	314	7	92	211	135

Dimensions in millimeters unless otherwise specified.

* J is the wrench clearance to allow for tightening and loosening the bushing on the shaft. The use of a shortened wrench will permit this dimension to be reduced

+ H is the distance between shaft ends.

++ Masses given are for couplings with mid-range Taper Bushes.

PART NUMBERS

Size	Catalogue Code HF	Catalogue Code FF
RM12	RM12HF	RM12FF
RM16	RM16HF	RM16FF
RM25	RM25HF	RM25FF
RM30	RM30HF	RM30FF
RM35	RM35HF	RM35FF
RM40	RM40HF	RM40FF
RM45	RM45HF	RM45FF
RM50	RM50HF	RM50FF

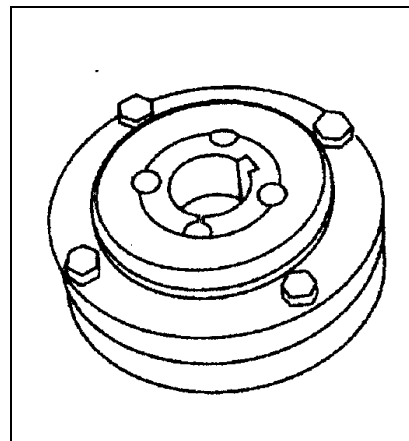

Coupling Installation

SHAFT ALIGNMENT

Appropriate alignment of the coupled shafts (or driven shaft to flywheel) is a fundamental requirement for any coupling installation.

The three basic modes of shaft misalignment are shown right.

Composite i.e. more than one mode, misalignment is available for some couplings (detailed elsewhere in this catalog).

Details of the degrees of misalignment that can be accommodated by different types and sizes of coupling which are given throughout this catalog.

With some couplings, axial shaft orientation (DBSE) is not critical, whereupon coupling component orientation (given as an 'assembled length' or 'distance between faces') becomes crucial.

Excepting Universal Joints under angular misalignment, it should be remembered that misalignment can cause extra loading on coupled shaft support bearings and can reduce the operational life of some couplings. Best practical alignment is therefore desirable. Taper Bush Rigid Couplings cannot accommodate misalignment.

OTHER CRITERIA

Martin - tyre gap and seating. Tyre/element clamping bolt torque.

HRC - do not use to couple resiliently mounted machinery.

All Elastomeric Couplings- consider ambient conditions (FRAS or other alternative element material required?)

All Taper Bush Couplings - bush grips the shaft first and draws hub on to taper. This may affect axial alignment.

All applications - ensure shaft diameter tolerances are correct.

NOTE **Martin** tyres, elements are accompanied by detailed installation data.

TAPER BUSH

Most of the **Martin-Flex** and HRC couplings, and all Rigid couplings featured in this section use Taper Bushes. For detailed instructions on the fitting and dismantling of Taper Bush products see Bushing Installation on page B-15.

Note: When fitting Taper Bush coupling flanges it should be noted that the bush grips the shaft initially and draws the flange up the tapered surface.

This may have a small effect on the final axial positioning of flanges on machine shafts, and the resultant distance between coupling flanges, where this is important to the fit and function of flexible coupling elements.

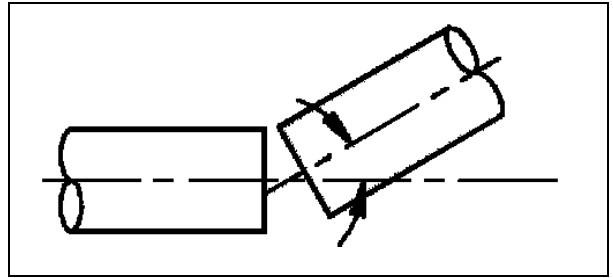

ANGULAR MISALIGNMENT - Shafts are at an angle to one another

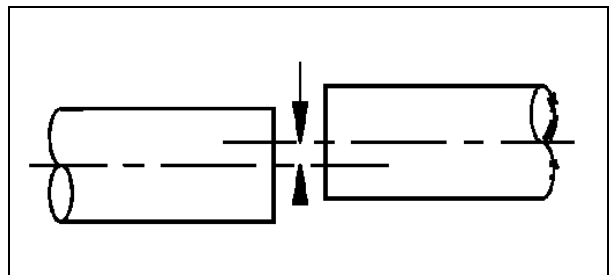

PARALLEL MISALIGNMENT - Shafts are in line angularly and parallel to each other, but are off-set.

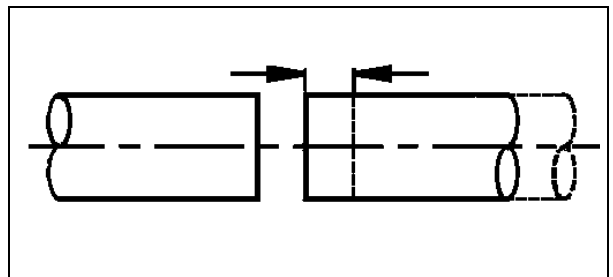

AXIAL MISALIGNMENT - includes applicable 'end float' - shafts move axially increasing or decreasing the distance between shaft ends.

Quadra-flex® FLEXIBLE COUPLINGS

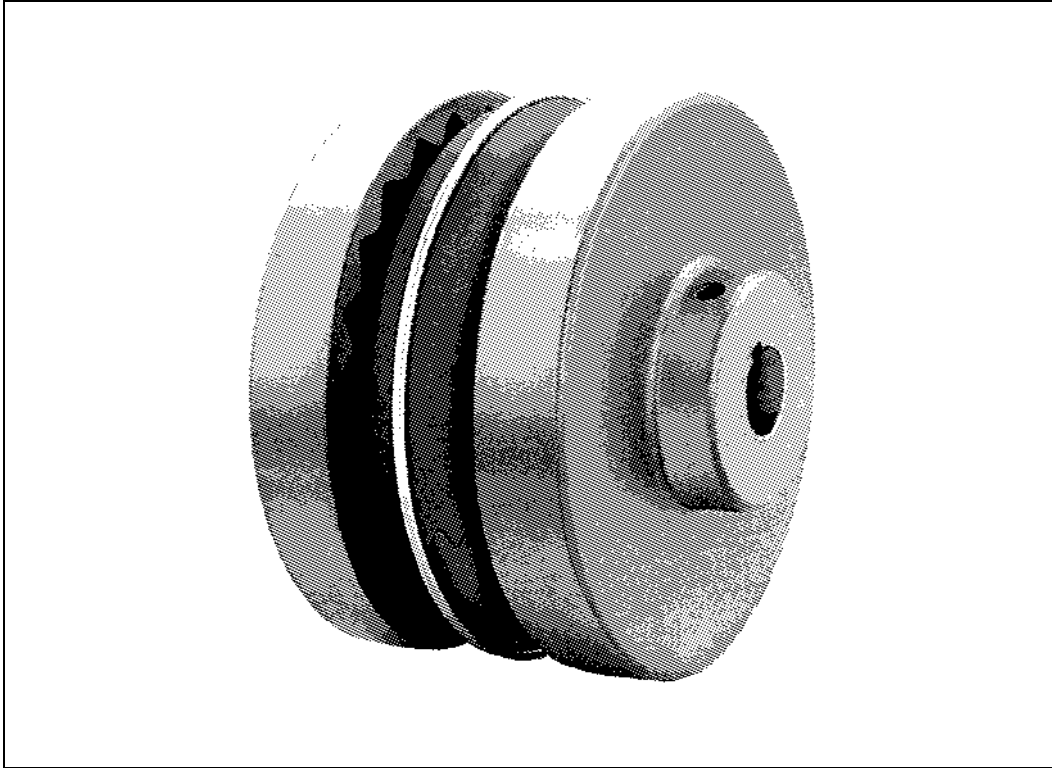

Currently Stocked in U.S.A. Only.



In Sizes 3 Through 16

Styles J, S, B, and
SC Spacers

QUADRA-FLEX® 4-Way Flexing



Martin QUADRA-FLEX® Couplings, Non Lubricated,
Maintenance Free, Easy and Quick Installation

Handles All Combinations of Shock, Vibration, and Misalignment

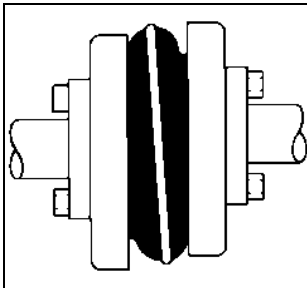

Parallel

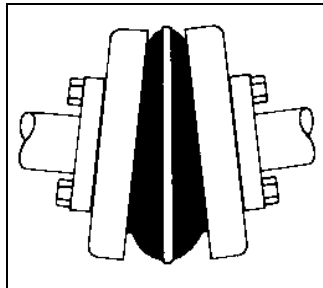

Angular

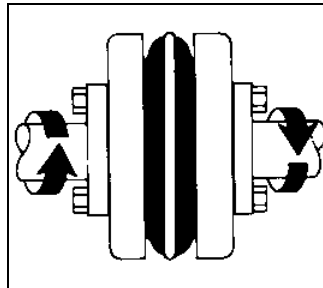

Torsional

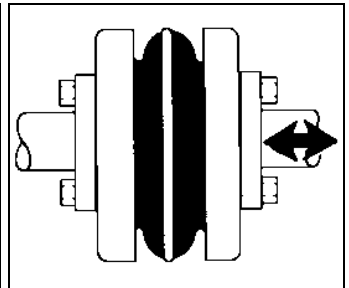

Axial

QUADRA-FLEX® couplings absorb parallel misalignment without wear and with minimal loss of energy. The amount of parallel offset handled varies by size from 0,4mm on the size 5 up to 1,6 mm on the size 16. This minimizes the radial loads on bearings when parallel misalignment occurs.

Due to the flexing characteristics of the sleeve and the locking action of the teeth, QUADRA-FLEX® couplings easily handle angular misalignment up to 1 degree without any appreciable wear.

QUADRA-FLEX® sleeves are torsionally resilient and are well suited to absorbing shocks and dampening vibrations that would otherwise be transmitted between the equipment.

The axial flexibility of the sleeve allows the QUADRA-FLEX® coupling to accept a limited amount of end float. This serves to reduce thrust loads transferred to bearings. QUADRA-FLEX® units will accept axial movement of approximately 3,2mm.

Available in Three Styles

Type J and S Flanges

Bored-to-size flanges are manufactured for a slip fit on standard shafting. Available from stock in a wide range of shaft sizes.



Type B Flanges

Manufactured from high strength cast iron to fit standard QD bushings in sizes 6 thru 16.



Fast Coupling Disassembly

Martin offers the first true drop-out spacer assembly for the 4JSC spacer coupling. The center portion of the spacer can be taken out, just as in the 5SC thru 14SC, by simply removing four cap screws in each hub. The couplings center section can then be lifted out and the pump gaskets exposed. Flats on the spacer hubs facilitate turning shafts with a wrench.

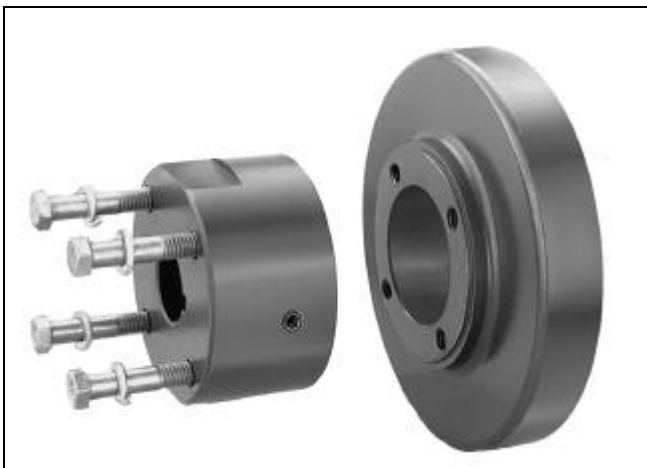

Type SC Spacer Flange

QUADRA-FLEX® SC Spacer Couplings feature all standard spacing requirements for the pump industry. Spacer sizes range from sizes 4 thru 14.



QUADRA-FLEX® Nomenclature

Flanges

Type	Description
J★	SINTERED STEEL, BORE-TO-SIZE
S	CAST IRON, BORED-TO-SIZE
B	CAST IRON, QD BUSHED
SC	SPACER COUPLING FLANGES

★ — #6 Currently Supplied in Cast Iron

Hubs – (For SC flanges)

Type	Description
H	REGULAR LENGTH
HS	SHORT LENGTH

Sleeves

Type	Description
JEM	TPR – 1-PIECE SOLID, THERMOPLASTIC
JEMS	TPR – 1-PIECE SPLIT, THERMOPLASTIC
EM	TPR – 2-PIECE W/RETAINING RING
E	EPDM – 2-PIECE W/RETAINING RING
N	NEOPRENE – 2-PIECE W/RETAINING RING
H	HYTREL – 1-PIECE SOLID
HS	HYTREL – 2-PIECE

QUADRA-FLEX® couplings come in a variety of styles and designs to meet specific customer needs. These include flanges and sleeves of various types and materials. The total product line includes 13 sizes varying in torque ratings up to 8135 Nm.

When ordering QUADRA-FLEX® couplings, the following basic procedure should help expedite order processing. For coupling flanges, give the basic coupling size, then the letter for the type flange followed by the bore size required. For coupling sleeves, give the coupling size followed by the letter(s) designating the type and material required. (See above)

The following are various examples for reference:

Example: Type J Flange

	<u>Size</u>	<u>Flange</u>	<u>Bore</u>
5J x 19,1mm	5	J	19,1 mm
7S x 30 mm	7	S	30 mm

(Note: Bored-to-size flanges are furnished with standard key-way and 2 setscrews unless specified otherwise.)

Example: Type B Flange

	<u>Size</u>	<u>Flange</u>	<u>Bushing</u>
8B — SH	8	B	SH

(Note: The SH bushing with required bore size should be specified separately.)

Example: Sleeves

	<u>Size</u>	<u>Style & Material</u>
8JEM	8	Solid, TPR
11E	11	2 Piece, EPDM

(Note: Unless specified, TPR (3 thru 10) or EPDM (11 thru 16) will be supplied.)

Example: Complete spacer coupling

1	6EM	(6 TPR 2 Piece Sleeve)
2	6SC35	(Flanges for 88.9mm dropout)
1	6H x 25,4mm	(6 Spacer Hub for 25.4mm Bore)
1	6H x 28,6mm	(6 Spacer Hub for 28.6mm Bore)



Sleeve Selection

QUADRA-FLEX® coupling sleeves are available in four different types of compounds. These include TPR (ThermoPlastic Rubber) in types JEM, JEMS, EM; EPDM Rubber in type E;

Neoprene in type N; Hytrel in type H and HS. To determine the sleeve best suited for the application, the material characteristics are given below.

TPR

(Sizes 3-10)

QUADRA-FLEX® couplings are usually supplied with TPR sleeves in sizes 3-10. TPR is a general use sleeve which combines the characteristics of both EPDM & Neoprene into one. These sleeves operate within a temperature range from -46°C to +135°C. (-50°F to + 275°F) Torsional flexibility is 15°.

EPDM

(Sizes 11-16)

QUADRA-FLEX® couplings are usually supplied with EPDM rubber sleeves in sizes 11-16. EPDM is a general use sleeve and can operate within a temperature range from -34°C to +135°C. (-30°F to +275°F) Torsional flexibility is 15°.

NEOPRENE★

(Sizes 13-16)

Neoprene flexible sleeves are also available in sizes 11-14. These sleeves offer a higher resistance than EPDM and are self-extinguishing. Operating temperature range for this sleeve is -18°C to +93°C. (0°F to +200°F) Torsional flexibility is 15°.

HYTREL★

(Sizes 6-14)

Hytrel sleeves are molded specifically for high torque applications. The type H will transmit approximately four times as much power as an equivalent TPR, EPDM, or Neoprene sleeve. Hytrel has an operating temperature from -54°C to +121°C. (65°F to +250°F) Torsional flexibility is 7°.

Note: Do not use a Hytrel sleeve as a replacement for a TPR, EPDM, or Neoprene sleeve.

Sleeve Chemical Resistance

Resistance To:	TPR	EPDM	Neoprene★	Hytrel★	Resistance To:	TPR	EPDM	Neoprene★	Hytrel★
Acetone	A	A	B	B	Isopropyl	A	T	A	A
Ammonia, Anhydrous	B	T	A	N	Kerosene	B	X	B	T
Ammonium Hydroxide Solutions	T	A	A(70C)	T	Lacquer Solvents	T	...	C	B
ASTM hydrocarbon test fluid	N	C	X	A	Lubricating Oils	B	X	B(70C)	A
ASTM oil no. 1	B	C	A	A	Methyl Alcohol	A	T	A(70C)	A
ASTM oil no. 3	B	C	B(70C)	A	Mineral Oil	B	X	A	A
ASTM reference fuel A	B	C	A	A	Naphtha	B	C	C	A
ASTM reference fuel B	B	C	C	A	Nitric Acid, 10%	A	T	B	B
ASTM reference fuel C	B	X	C	B	Nitrobenzene	T	A	C	C
Benzene	C	C	C	B	Phenol	T	T	B	C
Butane	B	B	A	A	Phosphoric Acid, 20%	A	T	T	N
Carbon Tetrachloride	X	C	C	C	Phosphate Esters	A	A	C	A
Chlorobenzene	C	X	X	X	Pickling Solution (20% Nitric Acid, 4% HF)	N	X	B-C	X
Chloroform	X	C	C	C	Soap Solutions	A	T	A(70C)	A
Chromic Acid, 10-50%	T	T	C	N	Sodium Hydroxide, 20%	A	A	A	A
Dowtherm A Solvent	X	N	B	N	Stearic Acid	T	T	B(70C)	T
Ethyl Alcohol	A	A	A(70C)	A	Sulfuric Acid, up to 50%	A	T	A(70C)	A
Ethylene Glycol	A	A	A(70C)	A	Sulfuric Acid, up to 80%	A	T	B-C	C
Fuel Oil	B	X	A	A	Tannic Acid, 10%	T	T	A	T
Gasoline	B	B-C	B	A	Toluene	C	C	C	B
Glycerine	A	T	A(70C)	A	Trichloroethylene	C	X	C	C
Hydraulic Oils	B	N	A	A	Turpentine	B	C	C	N
Hydrochloric Acid, 20%	A	T	A	B	Water	A	A(70C)	A(100C)	(70C)
Hydrogen Peroxide, 88% ^x	N	T	B	T	Xylene	C	C	X	B

A — Fluid has little or no effect
 B — Fluid has minor to moderate effect
 C — Fluid has severe effect

N — No evaluation has been attempted.
 T — No data; likely to be compatible
 X — No data; not likely to be compatible

★Registered Trademark of Dupont

Selection Procedure

When the driver is an electric motor with standard speed.

Step 1. Determine Service Factor (SF) Symbol based on equipment listed in Table 1 on page C-31.

Step 2. Determine proper Service Factor from chart at top of page C-31.

Step 3. Refer to page C-33 and C-34 for proper selection of coupling. Based on chemical resistance and operating environment found on page C-29, select from chart the type of sleeve material. Find RPM of motor, then, in the column for service factor determined in Step 2, read down to the corresponding kilowatt power of motor being used as the driver. The number listed is the correct coupling size.

Example: A coupling is needed to connect a 18,5 kW standard electric motor to a lumber log haul at 1450 RPM.

1. Service Factor Symbol — H
2. Service Factor — 2,0
3. Coupling Size — 10 with TPR sleeve or 6 with Hytrel Sleeve

Step 4. Select flanges from pages C-14 thru C-16, check coupling bore size range for proper shaft fit.

★ **NOTE: Do not oversize coupling hub — will cause premature wear of element.**

When the driver is other than an electric motor or the speeds are different than those shown in the chart on pages C-29 and C-30.

Step 1. Follow steps 1 & 2 in previous procedure.

Step 2. Calculate kW at 100 RPM as follows:

$$\text{kW at 100 RPM} = \frac{\text{kW} \times \text{Service Factor} \times 100}{\text{coupling RPM}}$$

Step 3. Select coupling size from Table 2. Find a HP equal to or greater than the kW/100 RPM

Step 4. Check Maximum bore to be sure that both shaft sizes do not exceed figure listed for size selected in step 4. If maximum is exceeded select the next largest size which will allow for bore size. Do not exceed maximum RPM for new size selected.

Example: A bucket elevator is driven by a motor/reducer and requires a coupling to transmit 10,4 kW at 1300 RPM.

1. Service Factor Symbol — M
2. Service Factor — 1.5
3. kW at 100 RPM = $\frac{10.4 \times 1.5 \times 100}{1300} = 1.20 \text{ kW/100 RPM}$
4. Refer to page C-32; under column for 100 RPM the required 1,20 kW falls between the size 7 (0,89) and the size 8 (1,30). Correct selection is size 8 with TPR sleeve. Check bore sizes for flanges on pages C-36 thru C-37.

Maximum RPM and Allowable Misalignment

Size	Maximum RPM	Types JEM, JEMS, EM, E and N		Types H and HS	
		Parallel	Angular	Parallel	Angular
3	9200	.010	.035	—	—
4	7600	.010	.043	—	—
5	7600	.015	.056	—	—
6	6000	.015	.070	.010	.016
7	5250	.020	.081	.012	.020
8	4500	.020	.094	.015	.025
9	3750	.025	.109	.017	.028
10	3600	.025	.128	.020	.032
11	3600	.032	.151	.022	.037
12	2800	.032	.175	.025	.042
13	2400	.040	.195	.030	.050
14	2200	.045	.242	.035	.060
16	1500	.062	.330	—	—

Note: Values shown above apply if the actual torque transmitted is more than 1/4 inch the coupling rating. For lesser torque, reduce the above values by 1/2 inch.



Service Factors For QUADRA-FLEX® Couplings

Service Factor Symbol	Electric Motor Standard Torque	Electric Motor High Torque	Turbines	Reciprocating Engines
L (LIGHT)	1,25	1,5	1,0	1,5
M (MEDIUM)	1,5	2,0	1,25	2,0
H (HEAVY)	2,0	2,5	1,5	2,5

Table 1

Application	SF Symbols	Application	SF Symbols	Application	SF Symbols
AGITATORS - Paddle, Propeller, Screw	.L	DISC FEEDER	.L	MILLS	
BAND RESAW	.M	DOUGH MIXER	.M	Ball, Pebble, Rod, Tube	.H
BARGE HAUL PULLER	.H	DRAW BENCH CONVEYOR & Main Drive	.H	Rubber, Tumbling	.H
BARKING (Lumber)	.H	DREDGES		Dryer and Cooler	.M
BAR SCREEN (sewage)	.L	Cable Reel, Pumps	.M	MIXER	
BATCHES (textile)	.L	Cutter Head Drive, Jig Drive	.H	Concrete, Muller	.M
BEATER AND PULPER (paper)	.M	Screen Drive	.H	Banbury	.H
BENDING ROLL (metal)	.M	Maneuvering and Utility Winch	.M	ORE CRUSHER	.H
BLEACHER (paper)	.L	Stacker	.M	OVEN CONVEYOR	.L
BLOWERS		DYNAMOMETER	.L	PLANER (metal or wood)	.M
Centrifugal, Vane	.L	DRYERS (rotary)	.M	PRESSES	
Lobe	.M	EDGER (lumber)	.H	Brick, Briquette Machine	.H
BOTTLING MACHINERY	.L	ELEVATORS		Notching, Paper, Punch, Printing	.M
BREW KETTLES (distilling)	.L	Bucket	.M	PUG MILL	.M
BUCKET ELEVATOR OR CONVEYOR	.M	Escalator	.L	PULP GRINDER (paper)	.H
CALENDERS		Freight, Passenger, Service, Man Lift	.H	PULVERIZERS	
Calender (paper)	.M	ESCALATORS	.L	Hammermill — light duty, Roller	.M
Calender-super (paper, rubber)	.H	EXTRUDER (metal)	.H	Hammermill — heavy duty, Hog	.H
CANE KNIVES (sugar)	.M	FANS		PUMPS	
CARD MACHINE (textile)	.H	Centrifugal	.L	Centrifugal, Axial	.L
CAR DUMPERS	.H	Cooling Tower	.H	Gear, Lobe, Vane	.M
CEMENT KILN	.H	Forced Draft, Large Industrial, Mine	.M	Reciprocating — sgl. or dbl. acting	.*
CENTRIFUGAL BLOWERS		FEEDERS		REEL, REWINDER (paper) CABLE	.M
COMPRESSORS, FANS or PUMPS	.L	Apron, Belt, Disc	.L	ROD MILL	.H
CHEMICAL FEEDERS (sewage)	.L	Reciprocating	.H	SAWDUST CONVEYOR	.L
CHILLER (oil)	.M	Screw	.M	SCREENS	
CHIPPER (paper)	.H	FILTER, PRESS-OIL	.M	Air Washing, Water	.L
CIRCULAR RESAW	.M	GENERATORS		Rotary for coal or sand	.M
CLARIFIER or CLASSIFIER	.L	Uniform load	.L	Vibrating	.H
CLAY WORKING MACHINERY	.M	Varying load, Holst	.M	SCREW CONVEYOR	.L
COLLECTORS (sewage)	.L	Welders	.H	SLAB CONVEYOR (lumber)	.M
COMPRESSORS		GRIT COLLECTOR (sewage)	.L	SLITTERS (metal)	.M
Centrifugal	.L	GRIZZLY	.H	SOAPERS (textile)	.L
Reciprocating	.*	HAMMERMILL		SORTING TABLE (lumber)	.M
Screw, Lobe	.L	Light Duty, Intermittent	.M	SPINNER (textile)	.M
CONCRETE MIXERS	.M	Heavy Duty, Continuous	.H	STOKER	.L
CONVERTING MACHINE (paper)	.M	HOISTS		SUCTION ROLL (paper)	.M
CONVEYORS		Heavy Duty	.H	TENTER FRAMES (textile)	.M
Apron, Assembly Belt, Flight	.L	Medium Duty	.M	TIRE BUILDING MACHINES	.H
Oven, Screw	.L	JORDAN (paper)	.H	TIRE & TUBE PRESS OPENER	.L
Bucket	.M	KILN, ROTARY	.H	TUMBLING BARRELS	.H
COOKERS- Brewing, Distilling, Food	.L	LAUNDRY WASHER or TUMBLER	.H	WASHER and THICKENER (paper)	.M
COOLING TOWER FANS	.H	LINE SHAFTS	.L	WINCHES	.M
COUCH (paper)	.M	LOG HAUL (lumber)	.H	WINDERS, Paper, Textile, Wire	.M
CRANES & HOISTS	.M	LOOM (textile)	.M	WINDLASS	.M
Heavy Duty Mine	.H	MACHINE TOOLS, MAIN DRIVE	.M	WIRE	
CRUSHERS — Cane (sugar), Stone, Ore	.H	MANGLE (textile)	.L	Drawing	.H
CUTTER — Paper	.H	MASH TUBS (distilling)	.L	Winding	.M
CYLINDER (paper)	.H	MEAT GRINDER	.M	WOODWORKING MACHINERY	.L
DEWATERING SCREEN (sewage)	.M	METAL FORMING MACHINES	.M		

* Consult Factory

Coupling Ratings



Coupling Ratings

Table 2A ThermoPlastic Rubber (TPR)

Coupling Size	Sleeve Construction	Basic Power Ratings (kW) Per Given RPM										Rated Torque (NM)	Maximum RPM
		100	250	500	725	950	1450	2000	2500	2850	3500		
3	TPR	0,07	0,18	0,35	0,51	0,67	1,0	1,4	1,8	2,0	2,5	6,78	9200
4	TPR	0,14	0,35	0,71	1,03	1,35	2,1	2,8	3,5	4,0	5,0	13,56	7600
5	TPR	0,28	0,71	1,42	2,06	2,70	4,1	5,7	7,1	8,1	9,9	27,12	7600
6	TPR	0,53	1,33	2,66	3,86	5,06	7,7	10,6	13,3	15,2	18,6	50,84	6000
7	TPR	0,86	2,14	4,29	6,22	8,15	12,4	17,2	21,4	24,4	30,0	81,91	5250
8	TPR	1,34	3,36	6,71	9,73	12,76	19,5	26,9	33,6	38,3	47,0	128,23	4500
9	TPR	2,13	5,32	10,65	15,44	20,23	30,9	42,6	53,2	60,7	74,5	203,36	3750
10	TPR	3,40	8,50	17,01	24,66	32,31	49,3	68,0	85,0	96,9	119,0	324,82	3600

Table 2B EPDM & Neoprene

Coupling Size	Sleeve Construction	Basic Power Ratings (kW) Per Given RPM										Rated Torque (NM)	Maximum RPM
		100	250	500	725	950	1450	2000	2500	2850	3500		
11	EPDM & Neoprene	5,4	13,4	26,8	38,9	50,9	77,7	107,2	134,0	152,7	187,6	511,8	3600
12	EPDM & Neoprene	8,5	21,3	42,6	61,8	80,9	123,5	170,4	212,9	—	—	813,5	2800
13	EPDM & Neoprene	13,4	33,6	67,1	97,3	127,6	194,7	268,5	335,7	—	—	1282,3	2400
14	EPDM & Neoprene	21,3	53,2	106,5	154,4	202,3	308,8	425,9	—	—	—	2033,6	2200
16	EPDM & Neoprene	55,9	139,7	279,5	405,3	531,0	810,5	—	—	—	—	5338,3	1500

Table 2C Hytel

Coupling Size	Sleeve Construction	Basic Power Ratings (kW) Per Given RPM										Rated Torque (NM)	Maximum RPM
		100	250	500	725	950	1450	2000	2500	2850	3500		
3*	Hytel	—	—	—	—	—	—	—	—	—	—	—	—
4*	Hytel	—	—	—	—	—	—	—	—	—	—	—	—
5*	Hytel	—	—	—	—	—	—	—	—	—	—	—	—
6	Hytel	2,1	5,3	10,6	15,4	20,2	30,9	42,6	53,2	60,7	74,5	203,4	6000
7	Hytel	3,4	8,5	17,0	24,7	32,3	49,3	68,0	85,0	96,9	119,0	324,8	5250
8	Hytel	5,5	13,7	27,4	39,7	52,0	79,4	109,5	136,9	156,1	191,7	523,1	4500
9	Hytel	8,5	21,3	42,6	61,8	80,9	123,5	170,4	212,9	242,8	298,1	813,5	3750
10	Hytel	13,4	33,6	67,1	97,3	127,6	194,7	268,5	335,7	382,7	470,0	1282,3	3600
11	Hytel	21,3	53,2	106,5	154,4	202,3	308,8	425,9	532,4	606,9	745,3	2033,6	3600
12	Hytel	37,3	93,2	186,3	270,2	354,0	540,4	745,3	931,6	—	—	3558,9	2800
13	Hytel	55,9	139,8	279,6	405,4	531,2	810,8	1118,4	—	—	—	5340,3	2400
14	Hytel	85,7	214,4	428,7	621,7	814,6	1243,3	—	—	—	—	8188,8	2200

, Hytel sleeves are available on a made-to-order basis. Consult factory.

• Values shown are for an ambient temperature of 24° C (75° F).



Sleeve Selection Chart

Selection Chart for TPR¹, EPDM, & Neoprene Sleeves

kW	725 RPM Motor Service Factors					960 RPM Motor Service Factors					1450 RPM Motor Service Factors					2850 RPM Motor Service Factors					
	1,0	1,25	1,5	2,0	2,5	1,0	1,25	1,5	2,0	2,5	1,0	1,25	1,5	2,0	2,5	1,0	1,25	1,5	2,0	2,5	
0,37	3	3	4	4	4	3	3	3	4	4	3	3	3	3	3	3	3	3	3	3	3
0,55	4	4	4	5	5	3	4	4	4	5	3	3	3	4	4	3	3	3	3	3	3
0,75	4	4	5	5	5	4	4	4	5	5	3	3	4	4	4	3	3	3	3	3	3
1,1	5	5	5	6	6	4	5	5	5	6	4	4	4	5	5	3	3	3	4	4	4
1,5	5	5	6	6	6	5	5	5	6	6	4	4	5	5	5	3	3	4	4	4	4
2,2	6	6	6	7	7	5	6	6	6	7	5	5	5	6	6	4	4	4	5	5	5
3,7	6	7	7	8	8	6	6	7	7	8	5	6	6	6	7	4	5	5	5	6	6
5,5	7	8	8	9	9	7	7	8	8	9	6	6	7	7	8	5	5	6	6	6	6
7,5	8	8	9	9	10	7	8	8	9	9	6	7	7	8	8	5	6	6	6	6	7
11	9	9	10	10	11	8	9	9	10	10	7	8	8	9	9	6	6	7	7	8	8
15	9	10	10	11	11	9	9	10	10	11	8	8	9	9	10	6	7	7	8	8	8
18,5	10	10	11	11	12	9	10	10	11	11	8	9	9	10	10	7	7	8	8	9	9
22	10	11	11	12	12	10	10	11	11	12	9	9	10	10	11	7	8	8	9	9	9
30	11	11	12	12	13	10	11	11	12	12	9	10	10	11	11	8	8	9	9	10	10
37	11	12	12	13	13	11	11	12	12	13	10	10	11	11	12	8	9	9	10	10	10
45	12	12	13	13	14	11	12	12	13	13	10	11	11	12	12	9	9	10	10	11	11
55	12	13	13	14	14	12	12	13	13	14	11	11	12	12	13	9	10	10	11	11	11
75	13	13	14	14	16	12	13	13	14	14	11	12	12	13	13	10	10	11	11	12	12
90	13	14	14	16	16	13	13	14	14	16	12	12	13	13	14	10	11	11	12	12	12
110	14	14	16	16	16	13	14	14	16	16	12	13	13	14	14	11	11	12	12	13	13
150	14	16	16	16	16	14	14	16	16	16	13	13	14	14	16	11	12	12	13	13	13
186	16	16	16	16	—	14	16	16	16	16	13	14	14	16	16	12	12	13	13	14	14
224	16	16	16	—	—	16	16	16	16	—	14	14	16	16	16	12	13	13	14	14	14
250	16	16	16	—	—	16	16	16	16	—	14	16	16	16	16	13	13	14	14	16	16
300	16	16	—	—	—	16	16	16	—	—	14	16	16	16	16	13	13	14	14	16	16
335	16	—	—	—	—	16	16	16	—	—	16	16	16	16	—	13	14	14	16	16	16
375	16	—	—	—	—	16	16	—	—	—	16	16	16	16	—	13	14	14	16	16	16
450	—	—	—	—	—	16	—	—	—	—	16	16	16	—	—	14	14	16	16	16	16
525	—	—	—	—	—	16	—	—	—	—	16	16	16	—	—	14	16	16	16	16	16
600	—	—	—	—	—	—	—	—	—	—	16	16	—	—	—	14	16	16	16	16	16

¹ ThermoPlastic Rubber

Caution: Applications involving reciprocating engines and reciprocating driven devices are subject to critical rotational speeds which may damage the coupling and/or connected equipment. Contact factory with specific requirements.

Hytrell Selection Chart



Selection Chart for Hytrell Sleeves

kW	725 RPM Motor Service Factors					960 RPM Motor Service Factors					1450 RPM Motor Service Factors					2850 RPM Motor Service Factors					
	1,0	1,25	1,5	2,0	2,5	1,0	1,25	1,5	2,0	2,5	1,0	1,25	1,5	2,0	2,5	1,0	1,25	1,5	2,0	2,5	
0,37	—	—	—	—	—	—	—	—	—	—	—	—	—	—	—	—	—	—	—	—	—
0,56	—	—	—	—	—	—	—	—	—	—	—	—	—	—	—	—	—	—	—	—	—
0,75	—	—	—	—	—	—	—	—	—	—	—	—	—	—	—	—	—	—	—	—	—
1,1	—	—	—	—	—	—	—	—	—	—	—	—	—	—	—	—	—	—	—	—	—
1,5	—	—	—	—	—	—	—	—	—	—	—	—	—	—	—	—	—	—	—	—	—
2,2	—	—	—	—	—	—	—	—	—	—	—	—	—	—	—	—	—	—	—	—	—
3,7	—	—	—	—	—	—	—	—	—	—	—	—	—	—	—	—	—	—	—	—	—
5,5	6HH	6HH	6H	6H	6H	—	—	—	—	—	—	—	—	—	—	—	—	—	—	—	—
7,5	6H	6H	6H	6H	7H	6H	6H	6H	6H	6H	—	—	—	—	—	—	—	—	—	—	—
11	6H	6H	7H	7H	8HH	6H	6H	6H	7H	7H	6H	6H	6H	6H	6H	—	—	—	—	—	—
15	6H	7H	7H	8H	8H	6H	6H	7H	7H	8H	6H	6H	6H	6H	7H	—	—	—	—	—	—
18,5	7H	7H	8H	8H	9H	6H	7H	7H	8H	8H	6H	6H	6H	7H	7H	—	—	—	—	—	—
22	7H	8H	8H	9H	9H	7H	7H	8H	8H	9H	6H	6H	7H	7H	8H	6H	6H	6H	6H	6H	6H
30	8H	8H	9H	9H	10H	7H	8H	8H	9H	9H	6H	7H	7H	8H	8H	6H	6H	6H	6H	6H	7H
37	8H	9H	9H	10H	10H	8H	8H	9H	9H	10H	7H	7H	8H	8H	9H	6H	6H	6H	7H	7H	7H
45	9H	9H	10H	10H	11H	8H	9H	9H	10H	10H	7H	8H	8H	9H	9H	6H	6H	7H	7H	8H	8H
55	9H	10H	10H	11H	11H	9H	9H	10H	10H	11H	8H	8H	9H	9H	10H	6H	7H	7H	8H	8H	8H
75	10H	10H	11H	11H	12H	9H	10H	10H	11H	11H	8H	9H	9H	10H	10H	7H	7H	8H	8H	8H	9H
90	10H	11H	11H	12H	12H	10H	10H	11H	11H	12H	9H	9H	10H	10H	11H	7H	8H	8H	8H	9H	9H
110	11H	11H	12H	12H	13H	10H	11H	11H	12H	12H	9H	10H	10H	11H	11H	8H	8H	9H	9H	10H	10H
150	11H	12H	12H	13H	13H	11H	11H	12H	12H	13H	10H	10H	11H	11H	12H	8H	9H	9H	10H	10H	10H
186	12H	12H	13H	13H	14H	11H	12H	12H	13H	13H	10H	11H	11H	12H	12H	9H	9H	10H	10H	10H	11H
224	12H	13H	13H	14H	14H	12H	12H	12H	13H	14H	11H	11H	12H	12H	13H	9H	10H	10H	10H	11H	11H
250	12H	13H	13H	14H	—	12H	12H	13H	13H	14H	11H	12H	12H	12H	13H	10H	10H	11H	11H	—	—
300	13H	13H	14H	14H	—	12H	13H	13H	14H	14H	11H	12H	12H	13H	13H	10H	10H	11H	11H	—	—
335	13H	14H	14H	—	—	12H	13H	13H	14H	—	12H	12H	12H	13H	14H	10H	11H	11H	—	—	—
375	13H	14H	14H	—	—	13H	13H	14H	14H	—	12H	12H	13H	13H	14H	10H	11H	11H	—	—	—
450	14H	14H	—	—	—	13H	14H	14H	—	—	12H	13H	13H	14H	14H	11H	11H	—	—	—	—
525	14H	—	—	—	—	13H	14H	14H	—	—	12H	13H	13H	14H	—	11H	—	—	—	—	—
600	14H	—	—	—	—	14H	14H	—	—	—	13H	13H	14H	14H	—	11H	—	—	—	—	—

QUADRA-FLEX® Sleeves

Martin flexible sleeve elements are offered in four material compounds (ThermoPlastic Rubber (TPR), EPDM, Neoprene, and Hytrel) available in three construction styles. Our EM sleeve offers the combination of EPDM's extended temperature range as well as the higher oil resistance which Neoprene provides.

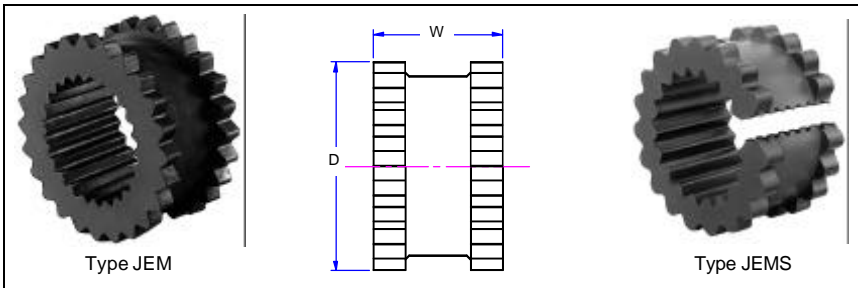

Types JEM — JEMS

Type J sleeves are molded ThermoPlastic Rubber (TPR). Available in 1 piece solid (JEM), and 1 piece split, construction (JEMS). TPR material will handle higher temperature ranges as well as be oil resistant.

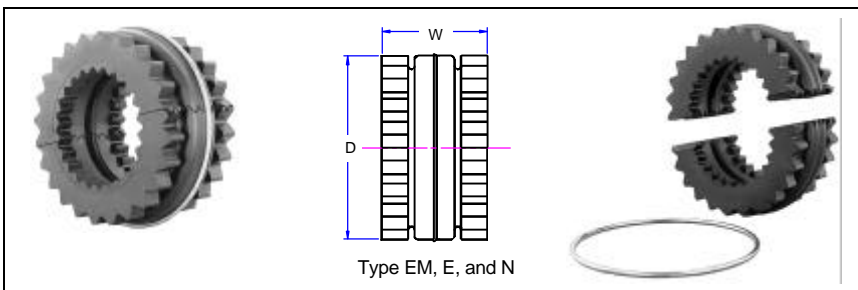

Types EM — E — N

Type EM, E, and N sleeves are of two piece molded construction with Retaining Ring. They are available in ThermoPlastic Rubber (Type TPR), EPDM (Type E), or Neoprene (Type N). These can be used with any type flanges within a given size range.

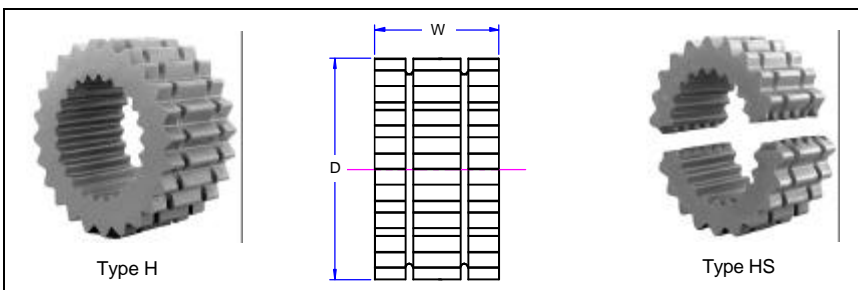

Types H & HS

Martin H & HS sleeves are molded Hytrel for higher torque loading than standard EM sleeves. H & HS sleeves cannot be used with style J and B flanges. Hytrel sleeves are not a direct replacement for TPR, EPDM, or Neoprene sleeves.

Dimensions (MM)

Coupling Size	JEM — JEMS Sleeves			EM Sleeves			E and N Sleeves EDPM and Hytrel			H & HS Sleeves Hytrel*		
	D	W	Wt. (Kg.)	D	W	Wt. (Kg.)	D	W	Wt. (Kg.)	D	W	Wt. (Kg.)
3	47,6	25,4	0,03	—	—	—	—	—	—	—	—	—
4	74,6	31,8	0,05	54,2	31,8	0,05	—	—	—	—	—	—
5	74,6	39,7	0,09	75,9	39,7	0,11	—	—	—	—	—	—
6	95,3	47,6	0,18	95,3	47,6	0,22	—	—	—	95,3	47,6	0,20
7	110,3	55,5	0,28	110,3	72,9	0,35	—	—	—	110,3	55,5	0,31
8	128,6	63,5	0,51	128,6	63,5	0,64	—	—	—	128,6	63,5	0,64
9	152,4	76,2	0,66	152,4	76,2	0,91	—	—	—	152,4	76,2	0,82
10	179,4	87,3	1,05	179,4	88,2	1,45	—	—	—	179,4	87,3	1,32
11	—	—	—	—	—	—	207,9	101,6	2,31	207,9	101,6	2,04
12	—	—	—	—	—	—	242,9	119,0	3,68	242,9	119,0	3,31
13	—	—	—	—	—	—	284,1	139,7	5,90	282,9	139,7	5,35
14	—	—	—	—	—	—	332,6	165,1	9,57	332,6	165,1	8,76
16	—	—	—	—	—	—	454,8	222,3	20,55	—	—	—

* 13 & 14 Hytrel available with HS sleeves only.

Type J Flanges



QUADRA-FLEX® Type J Flanges

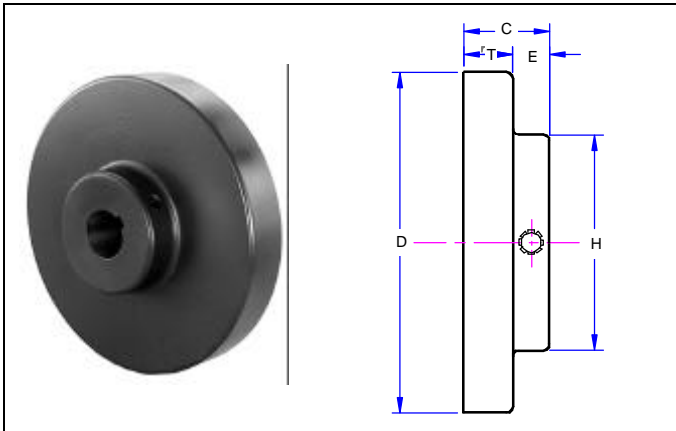

QUADRA-FLEX® Type J Flanges

Martin Type J Flanges are supplied bored to size with standard keyway and two setscrews to slip fit on standard shafting.

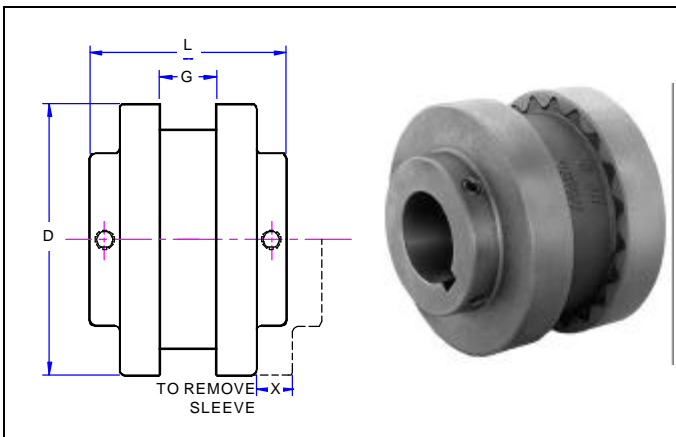

Type J Flanges use the Martin JEM 1 Piece, the Martin JEMS 1 piece split and the Martin EM 2 piece split sleeves.

(Note: Hytrel sleeves are not intended for use with this type of flange.)

Dimensions (mm)

Coupling Size	Dimensions (mm)									Weight (Kg.)★	Max. Bore	Finished Bore Sizes (mm)
	C	D	E	G	H	L	T	X				
3J	20,6	52,4	11,1	9,5	31,8	50,8	9,5	14,3	0,12	3/4	— — —	
	20,6	52,4	11,1	9,5	38,1	50,8	9,5	14,3	0,12	7/8	— — —	
4J	22,2	62,5	11,1	15,9	41,3	60,3	11,1	19,1	0,21	1	15 20 25	
5J	27,0	82,6	11,9	19,1	47,6	73,0	15,1	24,6	0,39	1 1/8	— — —	
6J	31,0	101,6	15,1	22,2	49,2	84,1	15,9	27,8	0,78	—	— — —	
	31,0	101,6	15,1	22,2	63,5	84,1	15,9	27,8	0,77	1 3/8	— — —	

* Approximate weight for each flange.
 • J flanges can be rebored if necessary.

Quadra-Flex Bores Type J Flanges

Coupling Size	Finished Bore Sizes	
	(Inches)	(mm)
3J	3/8 - 1/2 - 5/8 - 3/4 - 7/8	9* 11 12 14 15 16 19
4J	1/2 - 5/8 - 3/4 - 7/8 - 1 1/16 - 1	12* 14 15 16 17 20 24
5J	1/2 - 5/8 - 3/4 - 7/8 - 1 1/16 - 1 - 1 1/16 - 1 1/8	14 16 19 20 24 25 28
6J	5/8 - 3/4 - 7/8 - 1 1/16 - 1 - 1 1/16 - 1 1/8 - 1 3/16 - 1 1/4 - 1 5/16 - 1 3/8	15* 19 20 24 25 28 30 32 35 38

*No Keyway.

QUADRA-FLEX® Type S Couplings (Bored to Size)

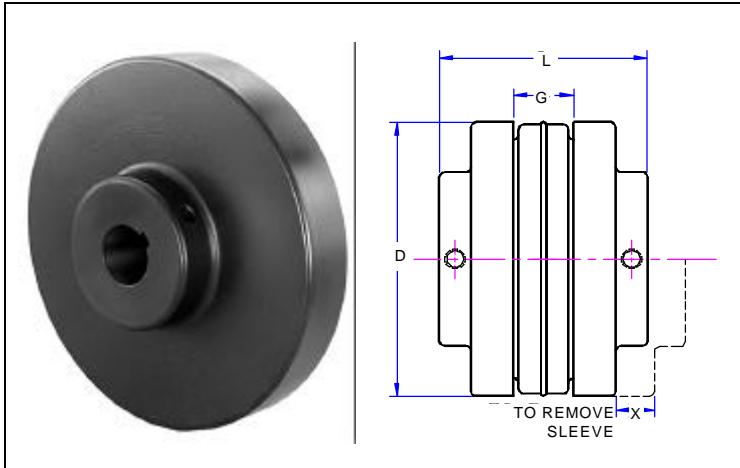

Type S flexible coupling flanges are bored to size to fit on any standard shaft. They are produced from high strength cast iron. Units are easy to install and remove and are stocked in a wide range of bore sizes as shown on the next page.

Dimensions

Coupling Size	Flange Diameter (OD)	Bore (MM)			Hub (MM)			G	L	T	X	Weight (Kg)•
		Stock	Rec. Max.★	Rec. Max.★★	Hub Diameter (H)	Length Thru (C)	Hub Proj. (E)					
5S	82,6	12	30,2	31,8	47,6	34,1	11,5	19,1	71,4	15,1	24,6	0,45
6S	101,6	15	36,5	38,1	63,5	41,3	13,5	22,2	88,9	19,8	27,8	0,95
	101,6	15	—	44,5	63,5	33,3	13,5	22,2	88,9	19,8	27,8	0,95
	101,6	15	—	47,6	71,4	39,7	19,8	22,2	101,6	19,8	27,8	0,95
7S	117,5	15	41,3	47,6	71,4	46,8	17,5	25,4	100,0	19,8	33,3	1,23
8S	138,4	18	49,2	57,2	82,6	53,2	19,1	28,6	112,7	23,0	38,1	2,04
	138,4	18	—	60,3	82,6	49,2	26,2	28,6	127,0	23,0	38,1	2,04
9S	161,3	22	60,3	63,5	92,1	61,1	19,8	36,5	128,6	26,2	44,5	2,95
	161,3	22	—	73,0	104,8	57,9	31,8	36,5	152,4	26,2	44,5	2,95
10S	190,5	28	69,9	79,4	111,1	67,5	20,6	41,3	144,5	31,0	50,8	5,13
	190,5	28	—	85,7	120,7	68,3	37,3	41,3	177,8	31,0	50,8	5,13
11S	219,1	30	57,2	—	95,3	87,3	28,6	47,6	181,0	38,1	60,3	7,99
	219,1	30	73,0	—	123,8	87,3	28,6	47,6	181,0	38,1	60,3	7,99
	219,1	30	85,7	92,1	133,4	87,3	28,6	47,6	181,1	38,1	60,3	7,99
	219,1	30	—	98,4	142,9	77,8	39,7	47,6	203,2	38,1	60,3	7,99
12S	254,0	38	57,2	—	95,3	101,6	32,5	58,7	209,6	42,9	68,3	12,34
	254,0	38	73,0	—	123,8	101,6	32,5	58,7	209,6	42,9	68,3	12,34
	254,0	38	98,4	100,0	146,1	101,6	32,5	58,7	209,6	42,9	68,3	12,34
13S	298,5	50	73,0	—	123,8	111,1	33,3	68,3	235,0	50,0	77,8	20,69
	298,5	50	114,3	—	171,5	111,1	33,3	68,3	235,0	50,0	77,8	20,69
14S	352,4	50	73,0	—	123,8	114,3	27,0	82,6	250,8	57,2	88,9	31,76
	352,4	50	127,0	—	190,5	114,3	27,0	82,6	250,8	57,2	88,9	31,76
16S	479,4	50	139,7	152,4	203,2	152,4	50,8	120,7	362,0	69,9	108,0	57,17

★ Recommended max. bore with standard keyway.

★★ Recommended max. bore with shallow keyway. See chart on page C-35 for recommended keyway size.

• Approximate weight for each flange.

Type S Flanges



Type S QUADRA-FLEX® Couplings Finished Bore Sizes

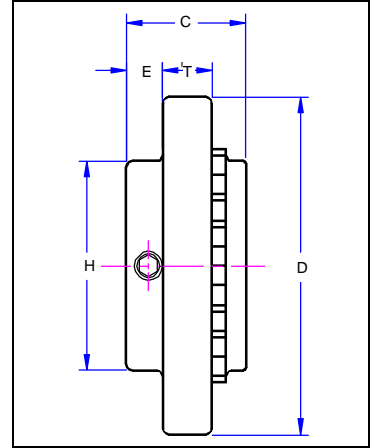

Quadra-Flex Bores Type S Flanges

Millimeter

Coupling Size	Finished Bore Sizes																		
	Millimeter																		
5S	14		16	19	20	24	25	28			35	38							
6S		15		19	20	24	25	28	30	32	35	38	42						
7S				19		24	25	28	30	32	35	38	42						
8S						24		28	30	32		38	42	45	48				
9S						24*			30	32		38	42	45	48				
10S									30	32	35	38	42	45	48	50	52	55	60

Inches

Coupling Size	Finished Bore Sizes																		
	Inches																		
5S	$\frac{5}{8}$	$\frac{3}{4}$	$1\frac{1}{16}$	$\frac{7}{8}$	$1\frac{1}{16}$	1	$1\frac{1}{16}$	$1\frac{1}{8}$	$1\frac{3}{16}$	$1\frac{1}{4}$									
6S	$\frac{3}{4}$	$\frac{7}{8}$	$1\frac{1}{16}$	1	$1\frac{1}{16}$	$1\frac{1}{8}$	$1\frac{3}{16}$	$1\frac{1}{4}$	$1\frac{5}{16}$	$1\frac{3}{8}$	$1\frac{7}{16}$	$1\frac{1}{2}$							
7S	$\frac{3}{4}$	$\frac{7}{8}$	$1\frac{1}{16}$	1	$1\frac{1}{16}$	$1\frac{1}{8}$	$1\frac{3}{16}$	$1\frac{1}{4}$	$1\frac{5}{16}$	$1\frac{3}{8}$	$1\frac{7}{16}$	$1\frac{1}{2}$	$1\frac{9}{16}$	$1\frac{5}{8}$	$1\frac{11}{16}$	$1\frac{3}{4}$	$1\frac{7}{8}$		
8S	$\frac{7}{8}$	$1\frac{1}{16}$	1	$1\frac{1}{8}$	$1\frac{3}{16}$	$1\frac{1}{4}$	$1\frac{5}{16}$	$1\frac{3}{8}$	$1\frac{7}{16}$	$1\frac{1}{2}$	$1\frac{5}{8}$	$1\frac{9}{16}$	$1\frac{3}{4}$	$1\frac{7}{8}$	$1\frac{11}{16}$	$2\frac{1}{8}$			
9S	1	$1\frac{1}{8}$	$1\frac{1}{4}$	$1\frac{3}{8}$	$1\frac{7}{16}$	$1\frac{1}{2}$	$1\frac{5}{8}$	$1\frac{3}{4}$	$1\frac{7}{8}$	$1\frac{9}{8}$	$1\frac{3}{4}$	$1\frac{7}{8}$	$1\frac{11}{8}$	$2\frac{1}{8}$	$2\frac{1}{16}$	$2\frac{3}{8}$	$2\frac{1}{2}$		
10S	$1\frac{1}{8}$	$1\frac{1}{4}$	$1\frac{3}{8}$	$1\frac{7}{16}$	$1\frac{1}{2}$	$1\frac{5}{8}$	$1\frac{7}{16}$	$1\frac{3}{4}$	$1\frac{7}{8}$	$1\frac{9}{8}$	2	$2\frac{1}{8}$	$2\frac{1}{16}$	$2\frac{1}{4}$	$2\frac{3}{8}$	$2\frac{1}{2}$	$2\frac{5}{8}$		
11S	$1\frac{1}{4}$	$1\frac{5}{8}$	$1\frac{3}{4}$	$1\frac{7}{8}$	$2\frac{1}{8}$														
12S	$1\frac{1}{8}$	$2\frac{1}{8}$																	
13S	$2\frac{1}{8}$	$2\frac{1}{4}$																	
14S	$2\frac{1}{8}$																		
16S	o																		

o Plain bore only.

Standard Keyway Dimensions (Metric)

Shaft Diameter		Key	Keyway Width	Keyway Depth
Over	Up to and Incl.			
6	8	2 x 2	2	1
8	10	3 x 3	3	1.4
10	12	4 x 4	4	1.8
12	17	5 x 5	5	2.3
17	22	6 x 2	6	2.8
22	30	8 x 7	8	3.3
30	38	10 x 8	10	3.3
38	44	12 x 8	12	3.3
44	50	14 x 9	14	3.8
50	58	16 x 10	16	4.3
58	65	18 x 11	18	4.4
65	75	20 x 12	20	4.9
78	85	22 x 14	22	5.4
85	95	25 x 14	25	5.4
95	110	28 x 16	28	6.4
110	130	32 x 18	32	7.4
130	150	36 x 20	36	8.4
150	170	40 x 22	40	9.4
170	200	45 x 25	45	10.4

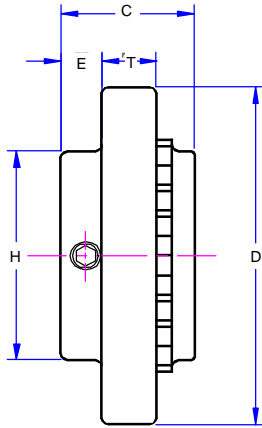

Bore Tolerances (Metric)

Stock Metric Bores are machined to a minimum H7 Tolerance.

Standard Keyway Dimensions (Imperial)

Shaft Diameter	Keyway	Width	Depth
$\frac{1}{2}$ - $\frac{3}{16}$	$\frac{1}{8} \times \frac{1}{8}$	$\frac{1}{8}$	$\frac{1}{16}$
$\frac{5}{8}$ - $\frac{7}{8}$	$\frac{3}{16} \times \frac{3}{16}$	$\frac{3}{16}$	$\frac{3}{32}$
$\frac{9}{16}$ - $1\frac{1}{4}$	$\frac{1}{4} \times \frac{1}{4}$	$\frac{1}{4}$	$\frac{1}{8}$
$1\frac{1}{2}$ - $1\frac{3}{8}$	$\frac{5}{16} \times \frac{5}{16}$	$\frac{5}{16}$	$\frac{3}{32}$
$1\frac{7}{8}$ - $1\frac{3}{4}$	$\frac{3}{8} \times \frac{3}{8}$	$\frac{3}{8}$	$\frac{3}{16}$
$1\frac{1}{2}$ - $2\frac{1}{4}$	$\frac{1}{2} \times \frac{1}{2}$	$\frac{1}{2}$	$\frac{1}{4}$
$2\frac{1}{2}$ - $2\frac{3}{4}$	$\frac{5}{8} \times \frac{5}{8}$	$\frac{5}{8}$	$\frac{3}{16}$
$2\frac{1}{2}$ - $3\frac{1}{4}$	$\frac{3}{4} \times \frac{3}{4}$	$\frac{3}{4}$	$\frac{3}{8}$
$3\frac{1}{2}$ - $3\frac{3}{4}$	$\frac{7}{8} \times \frac{7}{8}$	$\frac{7}{8}$	$\frac{7}{16}$
$3\frac{1}{2}$ - $4\frac{1}{2}$	1 x 1	1	$\frac{1}{2}$
$4\frac{1}{2}$ - $5\frac{1}{2}$	$1\frac{1}{4} \times 1\frac{1}{4}$	$1\frac{1}{4}$	$\frac{3}{8}$
$5\frac{1}{2}$ - $6\frac{1}{2}$	$1\frac{1}{2} \times 1\frac{1}{2}$	$1\frac{1}{2}$	$\frac{3}{4}$

Bore Tolerances (Imperial)

Bore (Inch)	Tolerance (Inch)
UP to 1	+0.0000 to +0.0010
$1\frac{1}{16}$ to $2\frac{1}{8}$	+0.0000 to +0.0015
$2\frac{1}{8}$ to $2\frac{3}{8}$	+0.0000 to +0.0020
$2\frac{3}{8}$ to $3\frac{1}{8}$	+0.0000 to +0.0025
$3\frac{1}{8}$ to $4\frac{1}{4}$	+0.0000 to +0.0030
$4\frac{1}{8}$ to 6	+0.0000 to +0.0035

These tolerances provide a slip fit.

Shallow Keyseat Dimensions (Imperial)

Coupling Size	Hub Dia. (mm) H	Length Thru (mm) C	Shallow Keyseat Dimensions								
			Bore	Keyway	Key	Bore	Keyway	Key	Bore	Keyway	Key
6S	63,5 71,4	33,3 39,7	$1\frac{5}{8}$	$\frac{3}{8} \times \frac{1}{8}$ $\frac{5}{8} \times \frac{1}{8}$	$\frac{3}{8} \times \frac{7}{16} \times 1\frac{1}{4}$	$1\frac{3}{4}$	$\frac{3}{8} \times \frac{1}{16}$	$\frac{3}{8} \times \frac{1}{4} \times 1\frac{1}{4}$	$1\frac{7}{8}$	$\frac{1}{2} \times \frac{1}{16}$	$\frac{1}{2} \times \frac{5}{16} \times 1\frac{1}{2}$
7S	71,4	46,8	$1\frac{7}{8}$	$\frac{1}{2} \times \frac{1}{8}$	$\frac{1}{2} \times \frac{3}{8} \times 1\frac{1}{8}$						
8S	82,6	55,6	$2\frac{1}{8}$	$\frac{1}{2} \times \frac{3}{16}$	$\frac{1}{2} \times \frac{7}{16} \times 2\frac{1}{16}$	$2\frac{3}{8}$	$\frac{5}{8} \times \frac{1}{8}$	$\frac{5}{8} \times \frac{7}{16} \times 1\frac{1}{8}$			
8S	82,6	49,2	$2\frac{1}{8}$	$\frac{1}{2} \times \frac{3}{16}$	$\frac{1}{2} \times \frac{7}{16} \times 2\frac{1}{16}$	$2\frac{3}{8}$	$\frac{5}{8} \times \frac{1}{8}$	$\frac{5}{8} \times \frac{7}{16} \times 1\frac{1}{8}$			
9S	92,1 104,8	61,1 57,9	$2\frac{1}{2}$	$\frac{5}{8} \times \frac{3}{16}$	$\frac{5}{8} \times \frac{3}{8} \times 2\frac{3}{8}$	$2\frac{7}{8}$	$\frac{3}{4} \times \frac{1}{8}$	$\frac{3}{4} \times \frac{1}{2} \times 2\frac{1}{16}$			
9S	92,1 104,8	61,1 57,9	$2\frac{1}{2}$	$\frac{5}{8} \times \frac{3}{16}$	$\frac{5}{8} \times \frac{3}{8} \times 2\frac{3}{8}$	$2\frac{7}{8}$	$\frac{3}{4} \times \frac{1}{8}$	$\frac{3}{4} \times \frac{1}{2} \times 2\frac{1}{16}$			
10S	111,1 120,7	67,5 68,3	$2\frac{7}{8}$	$\frac{3}{4} \times \frac{1}{4}$	$\frac{3}{4} \times \frac{5}{8} \times 2\frac{11}{16}$	$3\frac{3}{8}$	$\frac{7}{8} \times \frac{3}{16}$	$\frac{7}{8} \times \frac{3}{8} \times 2\frac{1}{16}$			
10S	111,1 120,7	67,5 68,3	$2\frac{7}{8}$	$\frac{3}{4} \times \frac{1}{4}$	$\frac{3}{4} \times \frac{5}{8} \times 2\frac{11}{16}$	$3\frac{3}{8}$	$\frac{7}{8} \times \frac{3}{16}$	$\frac{7}{8} \times \frac{3}{8} \times 2\frac{1}{16}$			
11S	82,6	87,3	$3\frac{7}{8}$	1 x $\frac{1}{4}$	1 x $\frac{3}{4} \times 3$						
	123,8	87,3	$3\frac{7}{8}$	1 x $\frac{1}{4}$	1 x $\frac{3}{4} \times 3$						
	133,4	87,3	$3\frac{7}{8}$	1 x $\frac{1}{4}$	1 x $\frac{3}{4} \times 3$						
	142,9	77,8	$3\frac{7}{8}$	1 x $\frac{1}{4}$	1 x $\frac{3}{4} \times 3$						
12S	95,3	101,6	$3\frac{1}{2}$	1 x $\frac{1}{4}$	1 x $\frac{3}{4} \times 3\frac{1}{16}$						
	123,8	101,6	$3\frac{1}{2}$	1 x $\frac{1}{4}$	1 x $\frac{3}{4} \times 3\frac{1}{16}$						
	146,1	101,6	$3\frac{1}{2}$	1 x $\frac{1}{4}$	1 x $\frac{3}{4} \times 3\frac{1}{16}$						

Type B Flanges

Type B Bushed QUADRA-FLEX®

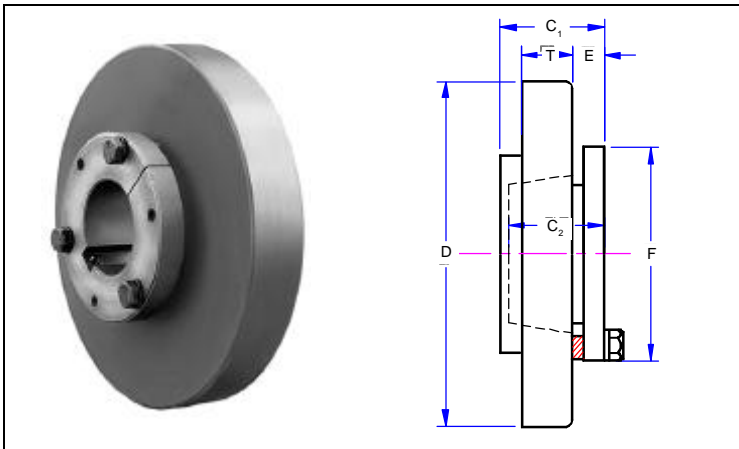

Flanges

Type B flanges are made of high quality cast iron. The same high strength cast iron used in the Type S and SC QUADRA-FLEX flanges. Type B is designed to accommodate Martin QD bushings for easy installation and removal. Type B flanges are not intended for use with Hyrel sleeves.

Coupling Size	Bushing Required	Dimensions (MM)									Max. Bore★	Weight (Kg.)†	
		C1	C2	D	E	F	G	L	T	X		Flange	Bushing
6B	JA	38,9	25,4	101,6	11,1	50,8	22,2	84,1	19,1	27,8	30,2	0,77	0,41
7B	JA	40,5	25,4	117,5	11,1	50,8	25,4	87,3	19,8	33,3	30,2	0,91	0,45
8B	SH	46,8	31,8	138,4	12,7	68,3	36,5	100,0	23,0	38,1	41,3	1,41	0,45
9B	SD	55,6	46,0	161,3	11,1	81,0	36,5	117,5	26,2	44,5	49,2	2,22	0,68
10B	SK	46,8	47,6	190,5	15,9	98,4	41,3	134,9	31,0	50,8	63,5	3,18	0,91
11B	SF	54,0	50,8	219,1	15,9	117,5	47,6	155,6	38,1	60,3	69,9	5,35	1,36
12B	E	68,3	66,7	254,0	22,2	152,4	58,7	188,9	42,9	68,3	87,3	7,80	4,54
13B	F	93,7	92,1	298,5	25,4	168,3	68,3	219,1	50,0	76,2	100,0	13,84	5,22
14B	F	93,7	92,1	352,4	25,4	168,3	82,6	247,7	57,2	88,9	100,0	23,14	5,22
16B	J	120,7	114,3	479,4	30,2	184,2	120,7	320,7	69,9	108,0	114,3	54,45	8,17

Dimensions in millimeters unless otherwise specified.

★ Maximum bore with keyseat.

† Approximate weight for each flange.

QD Bushing Keyway Dimensions (Imperial)

Bushing	Bores	Keyseat
JA	1/2 - 1	STANDARD
	1 1/16 - 1 1/8	1/4 x 1/16
	1 3/16	1/2 x 1/16
	1 1/4	NO K.S.
SH	1/2 - 1 3/8	STANDARD
	1 7/16 - 1 5/8	3/8 x 1/16
	1 1 1/16	NO K.S.
SD	1/2 - 1 1/4	STANDARD
	1 1/4	3/8 x 1/8
	1 1 1/8	1/2 x 1/8
	1 7/8 - 1 5/8	1/2 x 1/16
SK	2	NO K.S.
	1/2 - 2 1/8	STANDARD
	2 1/16 - 2 1/4	1/2 x 1/8
	2 3/16 - 2 1/2	5/8 x 1/16
SF	2 7/16 - 2 3/8	NO K.S.
	1/2 - 2 1/4	STANDARD
	2 3/16 - 2 1/2	3/8 x 3/16
	2 3/16 - 2 3/4	5/8 x 1/16
E	2 7/16 - 2 7/8	3/4 x 1/16
	2 1 1/16	3/4 x 1/32
	1/8 - 2 1/8	STANDARD
	2 3/16 - 3 1/4	3/4 x 1/8
F	3 3/16 - 3 1/16	7/8 x 1/16
	3 1/2	7/8 x 1/16
	1 - 3 1/16	STANDARD
	3 3/8 - 3 3/4	1 1/8 x 1/16
J	3 7/16 - 3 7/16	1 x 1/8
	4	NO K.S.
	1 1/4 - 3 1/4	STANDARD
	3 7/16 - 3 7/16	1 x 1/8
	4 - 4 1/2	1 x 1/8

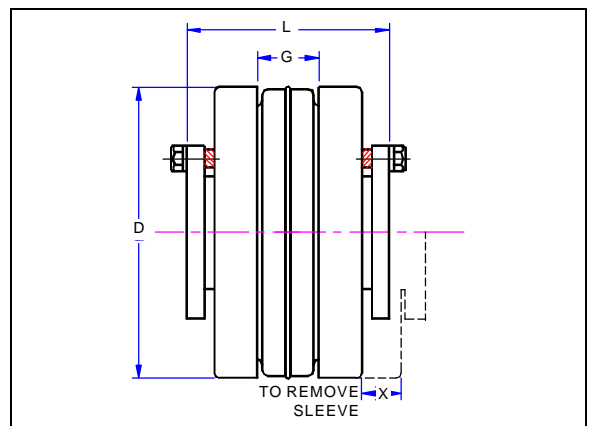

Bushings

Martin QD bushings offer convenient mounting of the flange to the shaft securely without setscrews. They are tapered and are split through both the bushing flange and taper to provide a clamp fit, eliminating wobble, vibration, and fretting corrosion. This is the same bushing used in Martin sprockets and sheaves and is readily available.

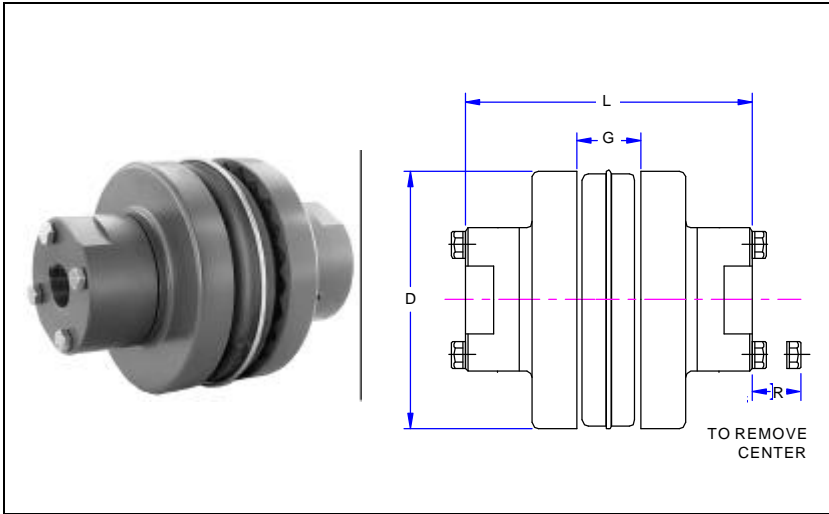

The dimensions for completely assembled QUADRA-FLEX® Type SC Spacer Couplings are shown below. See next page for dimensions of separate components.

Coupling Size	Required Distance Between Shafts	Use Flange Number	Use Hub Number	Max. Bore Standard Keyway	Dimensions				Weight ² (Kg.) [•]
					D	L ²	G	R	
4JSC	88,9	4JSC35	4H	28,6	62,5	142,9	15,9	12,7	2,13
5SC	88,9	5SC35	5H	28,6	82,6	142,9	19,1	14,3	1,86
6SC	88,9	6SC35	6H	34,9	101,6	149,2	22,2	19,1	3,22
6SC	111,1	6SC44	6H	34,9	101,6	171,5	22,2	19,1	3,58
6SC	127,0	6SC50	6H	34,9	101,6	187,3	22,2	19,1	3,86
7SC	88,9	7SC35	7H	41,3	117,5	161,9	25,4	15,9	4,13
7SC	111,1	7SC44	7H	41,3	117,5	184,2	25,4	15,9	4,58
7SC	127,0	7SC50	7H	41,3	117,5	200,0	25,4	15,9	4,85
8SC	88,9	8SC35	8H	47,6	138,4	174,6	28,6	20,6	6,67
8SC	88,9	8SC35-10	10H★	60,3	138,4	206,4	28,6	20,6	10,30
8SC	111,1	8SC44	8H	47,6	138,4	196,9	28,6	20,6	7,30
8SC	127,0	8SC50	8H	47,6	138,4	212,7	28,6	30,2	7,21
8SC	127,0	8SC50-10	10H★	60,3	138,4	244,5	28,6	30,2	12,02
9SC	88,9	9SC35	9H★	54,0	161,3	190,5	36,5	27,0	9,98
9SC	111,1	9SC44	9H★	54,0	161,3	209,6	36,5	27,0	10,62
9SC	127,0	9SC50	9H★	54,0	161,3	225,4	36,5	27,0	11,16
9SC	127,0	9SC50-11	11H★	73,0	161,3	263,5	36,5	30,2	18,24
9SC	177,8	9SC70-11	11H★	73,0	161,3	314,3	36,5	30,2	21,87
9SC	196,9	9SC78-11	11H★	73,0	161,3	333,4	36,5	30,2	23,05
10SC	120,7	10SC48	10H★	60,3	190,5	238,1	41,3	30,2	16,06
10SC	127,0	10SC50	10H★	60,3	190,5	244,5	41,3	30,2	17,33
10SC	177,8	10SC70-13	13H★	85,7	190,5	346,1	41,3	47,6	32,58
10SC	196,9	10SC78-13	13H★	85,7	190,5	365,1	41,3	47,6	34,30
10SC	254,0	10SC100-13	13H★	85,7	190,5	422,3	41,3	47,6	40,38
11SC	120,7	11 SC48	11H★	73,0	219,1	269,9	47,6	30,2	24,73
11SC	127,0	11 SC50	11H★	73,0	219,1	263,5	47,6	30,2	24,86
11SC	177,8	11SC70-14	14H	98,4	219,1	371,5	47,6	50,8	38,88
11SC	196,9	11SC78-14	14H	98,4	219,1	390,5	47,6	50,8	40,88
11SC	254,0	11SC100-14	14H	98,4	219,1	447,7	47,6	50,8	46,51
12SC	177,8	12SC70	12H★	73,0	254,0	327,0	58,7	38,1	39,79
12SC	177,8	12SC70-14	14H	98,4	254,0	371,5	58,7	50,8	44,87
12SC	196,9	12SC78	12H★	73,0	254,0	346,1	58,7	38,1	41,52
12SC	196,9	12SC78-14	14H	98,4	254,0	390,5	58,7	50,8	46,87
12SC	254,0	12SC100-14	14H	98,4	254,0	447,7	58,7	50,8	52,40
13SC	196,9	13SC78	13H★	85,7	298,5	365,1	68,3	47,6	55,26
14SC	196,9	14SC78	14H	98,4	352,4	390,5	82,6	50,8	81,40

Dimensions in millimeters unless otherwise specified.

★ Short (HS) hub also available.

• Approximate weight for completely assembled spacer coupling.

¹ 4JSC35 x 28,6 has a shallow keyway.

² "L" dimension and weight will change if one or two short (HS) hubs are used.

NOTE: Refer to page C-43 to order — specify components separately.

Type SC Flanges

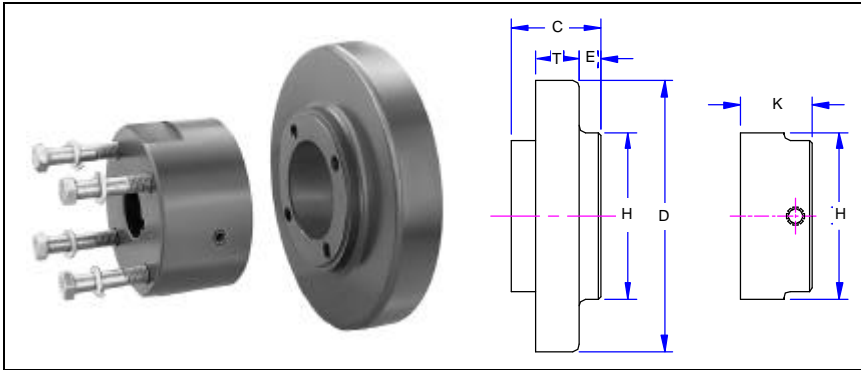

Type SC Flanges and Hubs

Tables below provide dimensional information for QUADRA-FLEX® Flanges and Hubs used for Spacer Couplings. Assembled dimensions are listed on opposite page. Any of the sleeves shown on page C-35 can be used.

Coupling Size	Flange Number	For Distance Between Shafts★	For Hub	Dimensions					Weight (Kg.)•	
				D	E	H	C	T		
4JSC	4SC35	88,9	4H	62,5	11,1	50,8	22,2	11,1	0,54	
5SC	5SC35	88,9	5H	82,6	20,2	50,8	42,9	15,1	0,54	
	6SC35	88,9	6H	101,6	14,5	63,5	41,3	19,1	0,91	
6SC	6SC44	111,1	6H	101,6	25,4	63,5	52,4	19,1	1,09	
	6SC50	127,0	6H	101,6	33,3	63,5	60,3	19,1	1,23	
7SC	7SC35	88,9	7H	117,5	11,9	71,4	41,3	19,8	1,04	
	7SC44	111,1	7H	117,5	23,0	71,4	52,4	19,8	1,27	
	7SC50	127,0	7H	117,5	31,0	71,4	60,3	19,8	1,41	
8SC	8SC35	88,9	8H	138,4	7,1	82,6	41,3	23,0	1,59	
	8SC35-10	88,9	10H-10HS	138,4	7,1	111,1	41,3	23,0	1,54	
	8SC44	111,1	8H	138,4	18,3	82,6	52,4	23,0	1,91	
	8SC50	127,0	8H	138,4	26,2	82,6	60,3	23,0	2,09	
8SC	8SC50-10	127,0	10H-10HS	138,4	26,2	111,1	60,3	23,0	2,40	
	9SC	9SC35	88,9	9H-9HS	161,3	1,6	92,1	42,9	26,2	2,31
		9SC44	111,1	9H-9HS	161,3	11,1	92,1	52,4	26,2	2,63
		9SC50	127,0	9H-9HS	161,3	19,1	92,1	60,3	26,2	2,90
9SC50-11		127,0	11H-11HS	161,3	19,1	133,4	60,3	26,2	3,13	
9SC70-11		177,8	11H-11HS	161,3	44,5	133,4	85,7	26,2	4,95	
9SC78-11	196,9	11H-11HS	161,3	54,0	133,4	95,3	26,2	5,49		
10SC	10SC48	120,7	10H-10HS	190,5	8,7	111,1	57,2	31,0	4,45	
	10SC50	127,0	10H-10HS	190,5	11,9	111,1	60,3	31,0	4,58	
	10SC70-13	177,8	13H-13HS	190,5	37,3	155,6	85,7	31,0	6,58	
	10SC78-13	196,9	13H-13HS	190,5	46,8	155,6	95,3	31,0	7,40	
	10SC100-13	254,0	13H-13HS	190,5	75,4	155,6	123,8	31,0	10,21	
11SC	11SC48	120,7	11H-11HS	219,1	1,3	133,4	38,1	39,4	5,67	
	11SC50	127,0	11H11HS	219,1	1,9	133,4	39,7	40,0	5,76	
	11SC70-14	177,8	14H	219,1	27,0	165,1	65,1	38,1	7,30	
	11SC78-14	177,8	14H	219,1	36,5	165,1	74,6	38,1	8,30	
11SC100-14	254,0	14H	219,1	65,1	165,1	103,2	38,1	11,12		
12SC	12SC70	177,8	12H-12HS	254,0	16,7	146,1	62,7	42,9	10,53	
	12SC70-14	177,8	14H	254,0	16,7	165,1	62,7	42,9	9,62	
	12SC78	196,9	12H-12HS	254,0	26,2	146,1	72,2	42,9	11,39	
	12SC78-14	196,9	14H	254,0	26,2	165,1	72,2	42,9	10,62	
12SC100-14	254,0	14H	254,0	54,8	165,1	100,8	42,9	13,38		
13SC	13SC78	196,9	13H-13HS	298,5	14,3	155,6	82,6	50,0	17,42	
14SC	14SC78	196,9	14H	352,4	1,0	165,1	69,1	57,2	24,95	

Dimensions in millimeters unless otherwise specified.

★ Flanges can be mixed to form different Between-Shaft Dimensions. See chart on page C-44.

• Approximate weight for each flange.

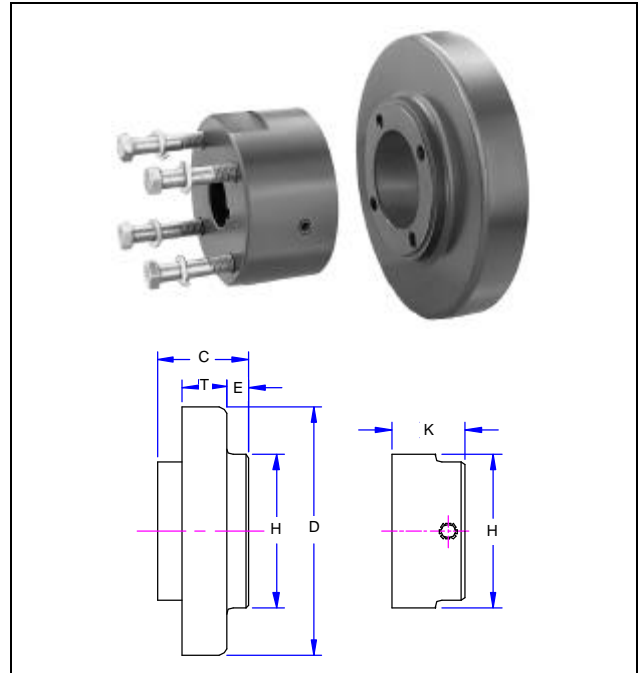
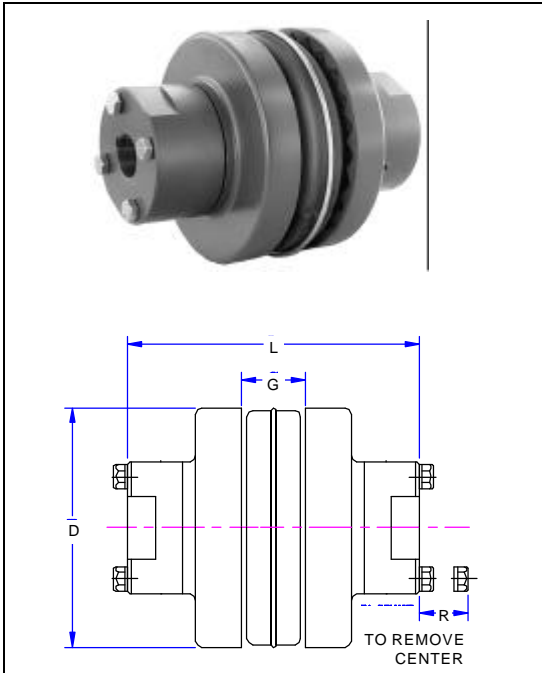

Coupling Size	Hub Number	Max. Bore (mm)	Plain Bore (Inches)	Stock Bores (Inches)	Dimensions			Weight (Kg.)•
				Bore with Standard Keyway and Setscrew	K (mm)	H (mm)	Cap Screws Furnished	
4JSC	4H	28,6	1/2	5/8 - 7/8 - 1 - 1 1/8★	41,3	50,8	4 — #10 x 2	0,50
5SC	5H	28,6	1/2	5/8 - 3/4 - 7/8 - 1 - 1 1/8	27,8	50,8	4 — #10 x 1 1/2	0,32
6SC	6H	34,9	5/8	3/4 - 7/8 - 1 - 1 1/8 - 1 1/4 - 1 3/8	31,0	63,5	4 — 1/4 x 1 3/4	0,59
7SC	7H	41,3	5/8	7/8 - 1 - 1 1/8 - 1 1/8 - 1 1/2 - 1 5/8	37,3	71,4	4 — 1/4 x 1 7/8	0,86
8SC	8H	47,6	3/4	7/8 - 1 - 1 1/8 - 1 1/8 - 1 1/2 - 1 5/8 - 1 3/4 - 1 7/8	43,7	82,6	4 — 5/16 x 2 1/4	1,45
9SC	9H	54,0	7/8	1 - 1 1/8 - 1 1/8 - 1 1/2 - 1 5/8 - 1 3/4 - 1 7/8 - 2 1/8	50,0	92,1	4 — 3/8 x 2 3/4	2,00
	9HS	38,1	1 1/8	38,9	92,1	4 — 3/8 x 2 1/4	1,68
10SC	10H	60,3	1 1/8	1 1/8 - 1 1/8 - 2 1/8 - 2 3/8	59,5	111,1	4 — 7/16 x 3	3,31
	10HS	41,3	1 1/8	42,1	111,1	4 — 7/16 x 2 1/2	2,50
11SC	11H	73,0	1 1/8	1 1/8 - 2 1/8 - 2 1/8 - 2 7/8	69,1	133,4	4 — 1/2 x 3 1/2	5,54
	11HS	47,6	1 1/8 - 1 5/8	48,4	133,4	4 — 1/2 x 2 3/4	4,22
12SC	12H	73,0	1 1/8	2 1/8 - 2 3/8 - 2 7/8	75,4	146,1	4 — 5/8 x 4	7,53
	12HS	63,5	2 3/8	64,3	146,1	4 — 5/8 x 3 1/2	6,40
13SC	13H	85,7	2 3/8 - 2 7/8 - 3 1/8	84,9	155,6	4 — 5/8 x 4 3/4	9,03
	13HS	63,5	2 7/8 - 2 3/8	62,7	155,6	4 — 5/8 x 3 1/2	7,26
14SC	14H	98,4	2 3/8 - 2 7/8 - 3 1/8 - 3 1/8	97,6	165,1	4 — 5/8 x 5	10,98

Dimensions in millimeters unless otherwise specified.

★ 4JSC x 28,6 has a shallow keyseat.

• Approximate weight for each hub.

Between-Shaft Spacings



QUADRA-FLEX® Between-Shaft Spacings

Spacer couplings are available with the most popular between shaft dimensions. Spacings other than standard can be achieved by mixing flanges.

The “Standard” column provides spacings using identical

flanges; the “Combination” column provides spacings with mixed flanges; the column headed “Semi-Spacer” uses one flange that is not made for spacer coupling and therefore does not have a detachable hub.

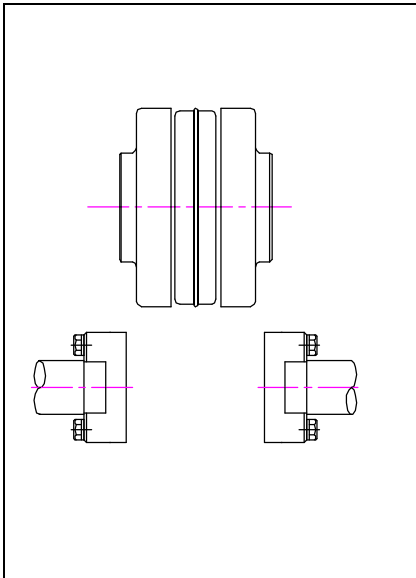

Standard

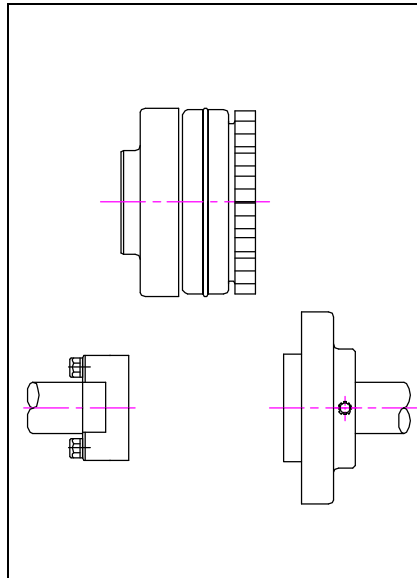

Combination

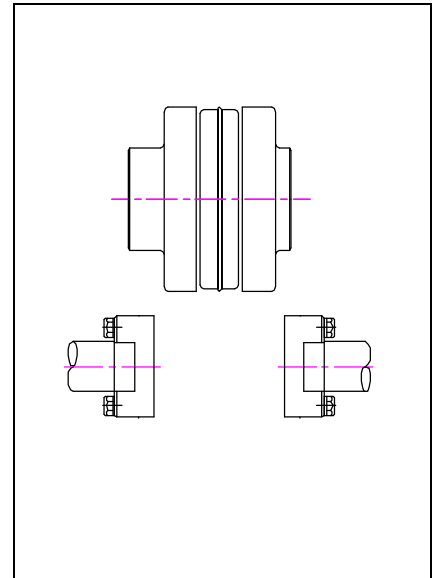

Semi-Spacer

Standard	
Spacing	Use Flanges★
88,9	2 - () SC35
111,1	2 - () SC44
127,0	2 - () SC50
177,8	2 - () SC70
196,9	2 - () SC78
254,0	2 - () SC100

Combination	
Spacing	Use Flanges★
100,0	SC35 & SC44
108,0	SC35 & SC50
119,1	SC44 & SC50
133,4	SC35 & SC70
142,9	SC35 & SC78
144,5	SC44 & SC70
152,4	SC50 & SC70
154,0	SC44 & SC78
161,9	SC50 & SC78
171,5	SC35 & SC100★★
182,6	SC44 & SC100★★
187,3	SC70 & SC78
190,5	SC50 & SC100
215,9	SC70 & SC100
225,4	SC78 & SC100

Semi-Spacer	
Spacing	Use Flanges★
47,6	S & SC35
58,7	S & SC44
66,7	S & SC50
92,1	S & SC70
101,6	S & SC78
130,2	S & SC100

Dimensions in millimeters unless otherwise stated.

★ Check individual coupling size for flange availability.

★★ Non-Stock

NOTE: Other combinations available — consult factory.

Martin QUADRA-FLEX® flanges (hubs) and elastomeric elements (sleeves) come in a wide range of sizes and types. First, determine the size and type of coupling components required. Remove all components from their boxes and loosely assemble the coupling. Do not install the wire ring on the two piece sleeves at this time. Check maximum RPM values in table against operating speeds.

Martin EM sleeves are rated the same as other EPDM and Neoprene sleeves, and may be used interchangeably; however, Hytrel sleeves are rated at different values and may not be interchanged with Martin EM sleeves, or the EPDM and Neoprene sleeves. Check horsepower and torque ratings when selecting Hytrel sleeves.



Step 1. Make sure the motor driving the part or components is locked out electrically in such a manner that it cannot be started by anyone, however remote from the area. The same type of lockout procedure applies to any other driving device which may be used. Failure to follow these instructions may result in personal injury or property damage.

Step 2. Prepare shafts for coupling installation. Inspect all coupling components and remove any protective coating or lubricants from bores, mating surfaces, and fasteners.

Step 3. Slide one coupling flange onto each prepared shaft using key stock where required. With the QD Type B flange, it may be necessary to expand the QD bushing bore for ease of installation.

Step 4. Position the flange on the shafts to achieve the approximate "Y" dimension (distance between flanges) shown in table. It is best to have equal shaft length into each flange. Tighten one flange in position, and slide the other flange sufficient distance back to install sleeve. Do not install wire ring on two piece sleeve in its final position at this time, but allow it to hang loosely in groove next to teeth.

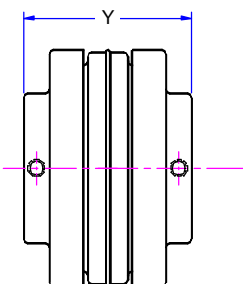

Step 5. Slide loose flange on the shaft until the sleeve has seated completely in teeth of both flanges. Refer to "Y" dimension although not a critical dimension. Secure the flange to shaft and torque set screws and cap screws to correct torque values.

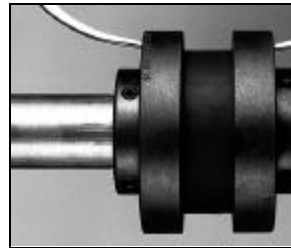

Parallel



Angular

Step 6. Check parallel alignment by placing a straight edge across the two coupling flanges and measure the maximum offset at several points around the periphery of coupling. **Do not** rotate coupling when taking these measurements. Refer to table for maximum allowed offset of parallel alignment. Realign the coupling if necessary.

Step 7. Check angular alignment with a micrometer, vernier, or caliper. Take measurement from outside to outside of flanges at several points around the periphery of coupling. **Do not** rotate coupling when taking these measurements. Determine the difference between maximum and minimum dimensions and check to make sure they do not exceed the angular figure on the table. If a correction is necessary, recheck parallel alignment.

Maximum RPM and Allowable Misalignment (Dimensions in MM)

Sleeve Size	Max-RPM	Types JEM, EM, E and N			★Type H & HS		
		Parallel	Angular	Y	Parallel	Angular	Y
3	9200	0,3	0,9	30,2	—	—	—
4	7600	0,3	1,1	38,1	—	—	—
5	7600	0,4	1,4	49,2	—	—	—
6	6000	0,4	1,8	61,9†	0,3	0,4	63,5
7	5250	0,5	2,1	65,1	0,3	0,5	66,7
8	4500	0,5	2,4	74,6	0,4	0,6	76,2
9	3750	0,6	2,8	88,9	0,4	0,7	90,5
10	3600	0,6	3,3	102,9	0,5	0,8	104,8
11	3600	0,8	3,8	123,8	0,6	0,9	125,4
12	2800	0,8	4,4	144,5	0,6	1,1	146,1
13	2400	1,0	5,0	169,9	0,8	1,3	169,9
14	2200	1,1	6,1	196,9	0,9	1,5	198,5
16	1500	1,6	8,4	260,4	—	—	—

NOTE: Values shown above may apply if the actual torque transmitted is more than 1/4 the coupling rating. For lesser torque, reduce the above values by 1/2.

★ Type H & HS sleeves should not be used as direct replacements for JEM or EM sleeves.

† Value when using 6J flanges is 54mm.

Step 8. If the coupling employs the two-piece sleeve with wire ring, install ring in center groove of sleeve.

Note: Some force may be required to seat the ring in groove.

Step 9. Install protective guards and/or shields per OSHA and any other additional local or state safety codes as required. (See Warning and Safety Reminder at beginning of Section 2.)

WARNING: Coupling sleeves may be forced from coupling when subjected to a severe shock load or abuse.

Stock Chain Couplings Taper Bushed Couplings



Type "TBH"



Type "TBF"

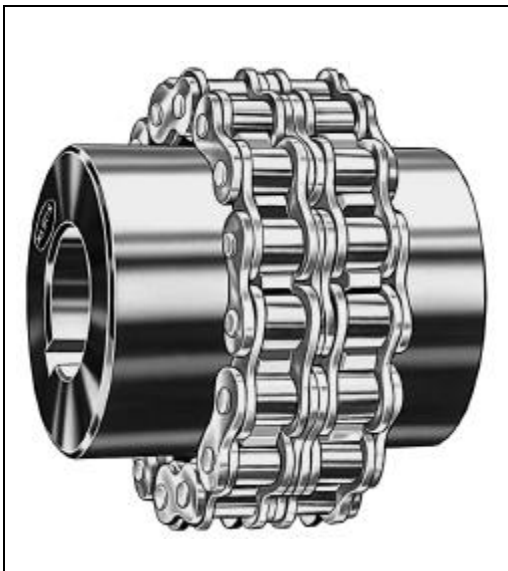

Bored to Size
and Stock Bore



Covers

Bored to Size Couplings With Finished Bore, Keyway, and Set Screw

Coupling Number	Stock Finished Bores												
	Include Standard Keyway and Setscrew												
IS0812	12,	16,	19										
IS0816	16,	19,	22,	24,	25,	28,	30,	32					
IS1016	16,	19,	22,	24,	25,	28,	30,	32,	35,	38,	40		
IS1018	19,	22,	24,	25,	28,	30,	32,	35,	38,	40,	45,	48,	50
IS1218	24,	25,	28,	30,	32,	35,	38,	40,	45,	48,	50,	55,	60
IS1220	28,	30,	35,	38,	45,	50,	55,	60,	65,				
IS1222	35,	38,	45,	50,	55,	60,	65,	70,	75				
IS1618	35,	38,	45,	50,	55,	60,	70,	75					
IS1620	38,	45,	55,	60,	70,	75,	80,	85,					
IS2018	55,	60,	80,	85,									
IS2020	80,	85,	90,	95,	100								
IS2418	85,	90,	95,	100,	110,								
IS2422	110,	115,	125										

Dimensions in millimeters unless otherwise specified.

CAUTION: All rotating power transmission products are potentially dangerous and must be properly guarded for the speeds and applications for which they were intended.

Bored to Size Coupling Dimensions

Coupling Number	A	B	C	L	Coupling O.D.	Approx. Wt. (Kg)
IS0812	35,7	28,96	7,1	65,0	61,1	0,23
IS0816	50,0	28,96	7,1	65,0	77,0	0,48
IS1016	63,5	36,88	9,5	83,3	96,0	0,98
IS1018	75,4	43,26	9,5	87,1	106,4	1,55
IS1218	88,9	47,6	11,1	106,3	127,0	2,43
IS1220	98,4	50,8	11,1	112,7	139,7	3,20
IS1222	114,3	54,0	11,1	119,1	151,2	4,46
IS1618	115,9	60,7	14,7	136,1	169,1	5,44
IS1620	136,5	66,1	14,7	146,9	185,3	8,04
IS2018	144,5	70,9	18,3	160,1	211,5	9,87
IS2020	170,7	79,8	18,3	177,9	231,8	14,96
IS2418	171,5	88,3	21,8	198,4	254,0	17,72
IS2422	222,3	102,1	21,8	226,0	302,0	30,00

Dimensions in millimeters unless otherwise specified.

Taper Bushed Couplings Type "TBH" and "TBF"

Type "TBH" Coupling Number	Type "TBF" Coupling Number	Bushing Data			A	B	C	J*	K†	L	OD	Weight (Kg.)
		Bushing Used	Max. Bore	Min. Bore								
IS0816TBH	IS0816TBF	1108	28,6	12,7	50,0	22,2	7,1	15,9	19,1	51,6	77,0	0,41
IS1018TBH	IS1018TBF	1610	41,3	12,7	75,4	25,4	9,5	20,6	27,0	60,3	106,4	0,50
IS1220TBH	IS1220TBF	2012	50,8	12,7	98,4	31,8	11,1	23,8	34,9	74,6	139,7	1,23
IS1620TBH	IS1620TBF	3020	76,2	23,8	136,5	50,0	14,7	30,2	52,4	116,3	185,3	2,77
IS2020TBH	IS2020TBF	3535	88,9	30,2	170,7	88,9	18,3	50,8	66,7	196,1	231,8	8,62

* Space needed for (1) tightening bushing with shortened hex key (2) loosening screws for puller to remove hub.

† Minimum clearance required to remove the coupling half by using the screws as jack screws with shortened hex key.

Dimensions in millimeters unless otherwise specified.

Our Standard Covers Fit These Couplings

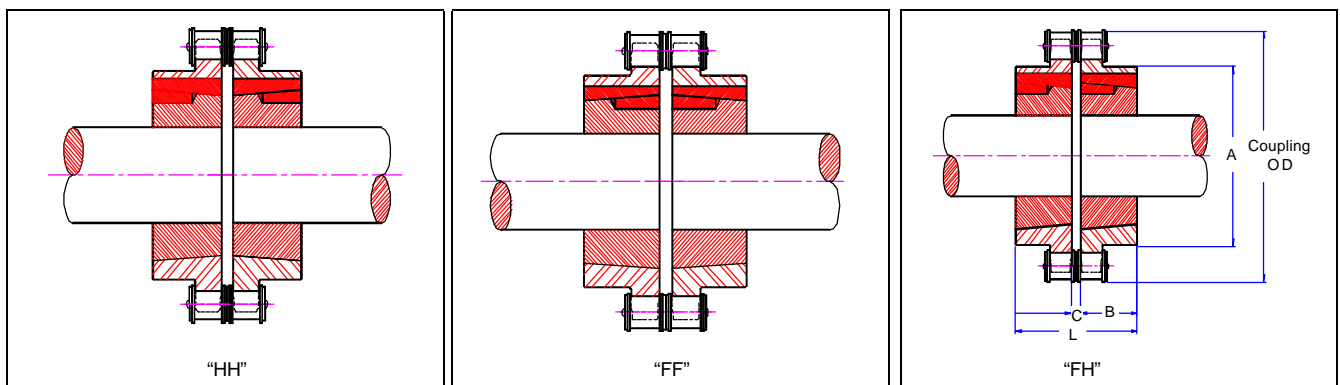

Stock Chain Couplings



Coupling Selection

Roller chain couplings have a torque capacity in excess of the torque normally transmitted by shafting which falls within the coupling bore range. Select the smallest coupling which will accommodate both shafts. For a reversing operation, shock or pulsating loads, or other severe operating conditions, select the next larger coupling size.

A cover should be used to assure maximum service life, particularly if the coupling operates at high speeds or under moist conditions. For proper lubrication, fill the space between the cover and the coupling with soft to medium consistency coupling grease.

Coupling With Plain Bores for Reboring

Coupling Number	Maximum Bore (MM)	Minimum Plain Bore (MM)	Weight (Kg.)	Recommended Maximum RPM	Coupling Chain Number	Weight (Kg.)
IS0812	22,2	11,1	0,23	5000	IS0812 CHN	0,18
IS0816	23,8	15,9	0,45	5000	IS0816 CHN	0,23
IS1016	42,9	15,9	1,00	4000	IS1016 CHN	0,54
IS1018	50,8	19,1	1,59	3600	IS1018 CHN	0,59
IS1218	61,9	25,4	2,27	3000	IS1218 CHN	1,00
IS1220	69,9	28,6	2,95	2500	IS1220 CHN	1,18
IS1222	76,2	28,6	4,31	2500	IS1222 CHN	1,23
IS1618	79,4	28,6	4,99	2000	IS1618 CHN	2,40
IS1620	90,5	38,1	7,40	2000	IS1620 CHN	2,68
IS2018	98,4	38,1	9,21	1800	IS2018 CHN	4,45
IS2020	117,5	38,1	14,43	1800	IS2020 CHN	4,95
IS2418	119,1	50,8	16,70	1500	IS2418 CHN	7,85
IS2422	155,6	50,8	31,76	1200	IS2422 CHN	9,62

Dimensions in millimeters unless otherwise specified.

Stock Coupling Covers

Covers fit Taper Bushed, Stock, and Finished Bore Couplings. Covers allow excellent lubrication, and their use is recommended to obtain maximum coupling life. Covers are of aluminum and Plastic and are made in halves for easy installation. Synthetic rubber oil seals, which contact the coupling hubs, retain the lubricant and prevent the entry of dirt. Covers are fitted with gaskets between the halves.

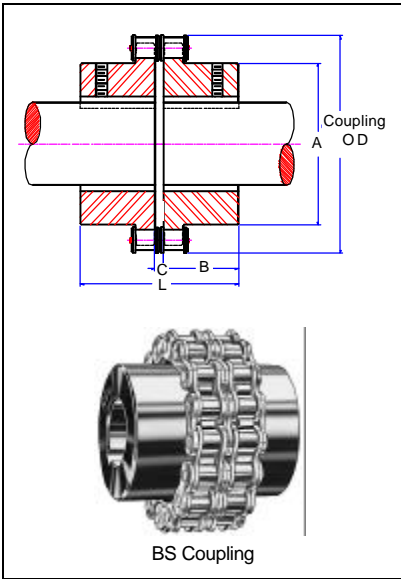

BS Coupling

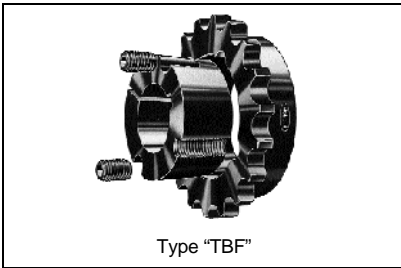

Type "TBF"

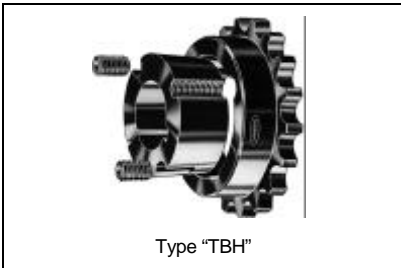

Type "TBH"

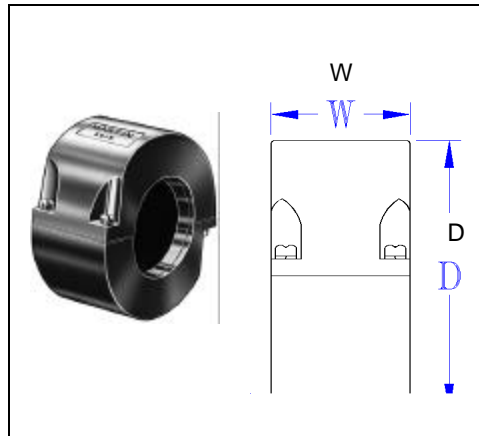

Aluminum
and
Plastic

Cover Cat. No.	Aluminum		Plastic		Wt. (Kg.)
	D	W	D	W	
IS0812COV**	101,6	50,8	101,6	58,7	,35
IS0816COV**	101,6	50,8	101,6	58,7	,42
IS1016COV**	130,2	60,3	130,2	66,7	,59
IS1018COV**	130,2	60,3	130,2	66,7	,59
IS1218COV**	161,9	74,6	161,9	77,8	1,11
IS1220COV**	161,9	74,6	161,9	77,8	1,11
IS1222COV*	208	101,6	208	101,6	2,21
IS1618COV	208	101,6	208	101,6	2,21
IS1620COV	208	101,6	208	101,6	2,21
IS2018COV	238,1	150,8	238,1	150,8	3,97
IS2020COV	257,2	133,4	257,2	133,4	5,74
IS2418COV	288,9	187,3	288,9	187,3	7,47
IS2422COV	336,6	201,6	336,6	201,6	8,85

Dimensions in millimeters unless otherwise specified.

* Use IS1613 cover — Special Seals Available

** Furnished in Plastic.

All Martin couplings have hardened teeth.

“MRC®” Gear Coupling

Martin's Gear Couplings provide a low cost alternative in applications where low power requirements are used. They provide an excellent way to compensate for axial, radial and angular misalignment of connecting shafts.



Pilot Bore and Finished Bore

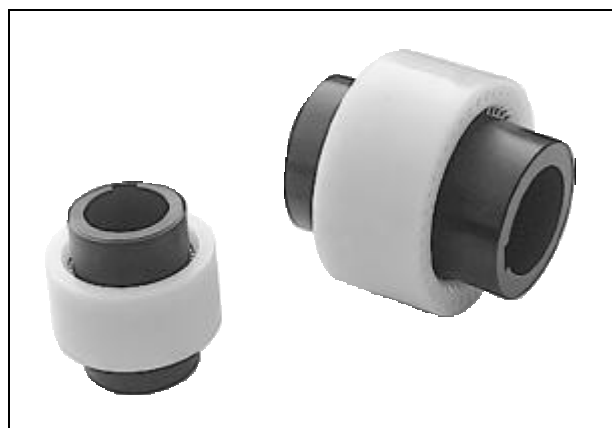

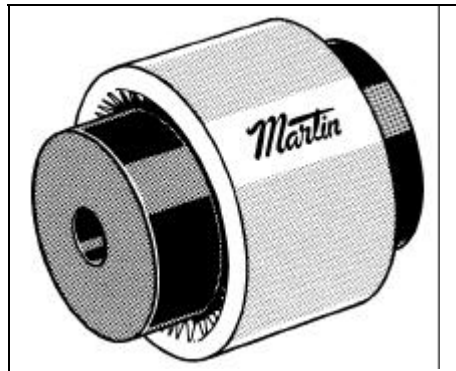

- Compact and lightweight design
- High Torque
- Power Ratings from, 37kW — 450kW
- 82°C Continuous ambient operating temperature
- Split fit and Blind assembly
- Minimum shaft gap
- No metal to metal contact — electrically isolated
- No seals or retainers to maintain
- No lubrication
- Resists most contaminating elements
- Stocked in a wide range of bore sizes

Double cardinal curved tooth with unique, smooth rounded profile

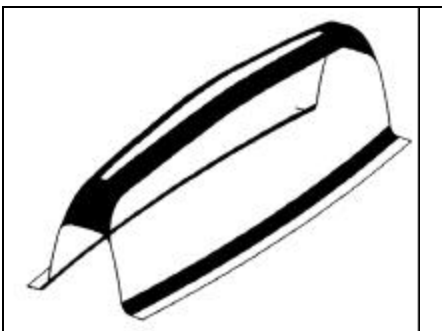

Gear Coupling

- Double cardanic curved tooth
 - *residual force due to axial-radial and angular misalignment is minimized;
- Full machined tooth
 - *symmetrical and even tooth form maximize performance of double cardan action between coupling components,
- Unique and smooth rounded tip relief profile,
 - *higher torque transmission under misalignment conditions,
 - *prevent stress raising on the plastic component to ensure smooth, low friction rotation;
- Low weight and minimum dimensions
 - *easy assembling in limited space;
- Available from stock with H7 fit, standard keyway finish-bores.



Gear Couplings

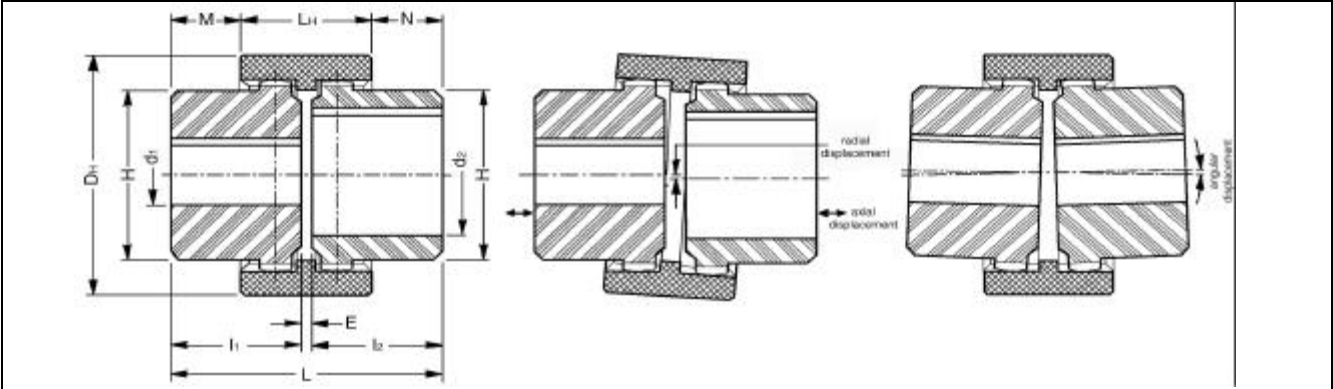

Gear Couplings — Dimensions

Coupling Size	Assembled Length (L)	Bore		(L ₁ & L ₂)	H	Length of Hub (mm)	Gap E	M & N	LH	Sleeve Dia. DH	Approx. Weight (Kg)
		Stock	Max.								
14	50	4	14	23	25	Up to 40	4	6,5	37	40	,19
19	54	10	19	25	32	Up to 40	4	8,5	37	48	,23
24	56	10	24	26	36	Up to 50	4	7,5	41	52	,32
28	84	10	28	40	44	Up to 55	4	19	46	66	,73
32	84	12	32	40	50	Up to 55	4	18	48	76	,96
38	84	12	38	40	58	Up to 60	4	18	48	83	1,23
42	88	15	42	42	65	Up to 60	4	19	50	92	1,50
48	104	15	48	50	68	Up to 60	4	27	50	100	1,82
55	124	15	55	60	82	Up to 70	4	29,5	65	120	4,20
65	144	15	65	70	96	Up to 70	4	36	72	140	5,20

*Note: See finished bore chart for additional stock sizes.

Gear Couplings — Available in the following Finished Bore.

Coupling Size	Finish bores (mm) H7, keyway to DIN 6885 sh.1 (JS9) and setscrew																														
	8	9	10	11	12	13	14	15	16	17	18	19	20	22	24	25	28	30	32	35	38	40	42	45	48	50	55	60	65	70	75
MRC14																															
MRC19																															
MRC24																															
MRC28																															
MRC32																															
MRC38																															
MRC42																															
MRC48																															
MRC55																															
MRC65																															

Standard Length.

Gear Couplings



Gear Couplings — Dimensions

Coupling Size	Bore		Nominal Torque		Max. Torque		Alignment Tolerances			Max. Speed RPM
	Stock	Max.	Nm	In. Lbs.	Nm	In. Lbs.	Max. Axial	Parallel	Angular	
14	4	14	10	86	20	173	±1	±0,3	±1	14000
19	10	19	16	138	32	277		11800		
24	10	24	20	173	40	347		10600		
28	10	28	45	390	90	781		8500		
32	12	32	60	520	120	1041		7500		
38	12	38	80	694	160	1388		6700		
42	15	42	100	868	200	1736		6000		
48	15	48	140	1215	280	2430		5600		
55	15	55	270	2344	540	4686		4800		
65	15	65	380	3298	760	6596		4000		

*Nominal Torque ratings will allow for 82°C (180°F) ambient, full misalignment and/or maximum RPM.

*Transient, intermittent peak loads should not exceed 3 times nominal torque.

+Starting torque and breaking loads should not exceed listed maximum torque.

+Applications with properly aligned shafts, low speeds and uniform loading will permit operation at maximum torque levels.

ASSEMBLY

1. When possible, hubs should be mounted flush with the end of the shaft.
2. Maintain recommended shaft gap whenever possible.
3. After assembly, check coupling length.
4. After final assembly, check to make sure the sleeve moves freely in an axial direction.

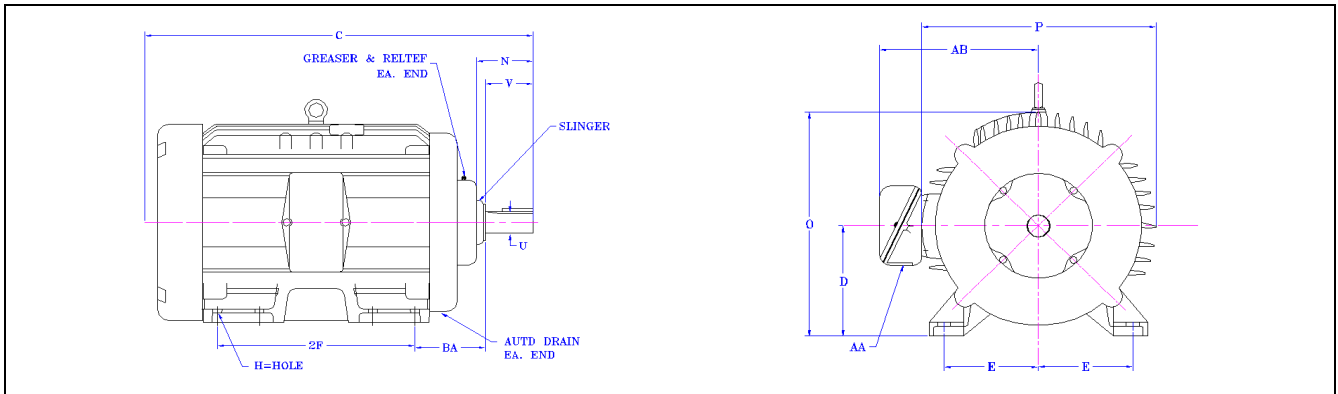

Gear Couplings for Standard IEC-Motors

A.C. Motor Size	Motor Output at 50Hz n= 3000 (1/min)		Gear Coupling	Motor Output at 50Hz n= 1500 (1/min)		Gear Coupling	Motor Output at 50Hz n= 1000 (1/min)		Gear Coupling	Motor Output at 50Hz n= 750 (1/min)		Gear Coupling	Shaft End dx1 (mm) 3000<=1500
	Power kW	T (Nm)		Power kW	T (Nm)		Power kW	T (Nm)		Power kW	T (Nm)		
56	0.09	0.32		0.06	0.43		0.037	0.43					9x20
	0.12	0.41		0.09	0.64		0.045	0.52					
63	0.18	0.62	14	0.12	0.88	14	0.06	0.72	14			14	11x23
	0.25	0.86		0.18	1.3		0.09	1.1					
71	0.37	1.3		0.25	1.8		0.18	2		0.09	1.4		14x30
	0.55	1.9		0.37	2.5		0.25	2.7		0.12	1.8		
80	0.75	2.5	19	0.55	3.7	19	0.37	3.9	19	0.18	2.5	19	19x40
	1.1	3.7		0.75	5.1		0.55	5.8		0.25	3.5		
90S	1.5	5	24	1.1	7.5	24	0.75	8	24	0.37	5.3	24	24x50
90L	2.2	7.4		1.5	10		1.1	12		0.55	7.9		
100L	3	9.8		2.2	15		1.5	15		0.75	11		
			28	3	20	28			28	1.1	16	28	28x60
112M	4	13		4	27		2.2	22		1.5	21		
132S	5.5	18		5.5	36		3	30		2.2	30		
	7.5	25	38			38			38			38	38x80
132M				7.5	49		4	40		3	40		
							5.5	55					
160M	11	36		11	72		7.5	75		4	54		
	15	49	42			42			42	5.5	74	42	42x110
160L	18.5	60		15	98		11	108		7.5	100		
180M	22	71	48	18.5	121	48			48			48	48x110
180L				22	144		15	148		11	145		
200L	30	97		30	196		18.5	181		15	198		55x110
	37	120					22	215					
225S				37	240	65			65	18.5	244	65	55x110
225M	45	145		45	292		30	293		22	290		60x140
250M	55	177	65	55	356		37	361		30	392		65x140
280S	75	241											75x140
280M	90	289											
315S	110	353											80x170

Polyamide resin transmission ring with low friction glossy surface

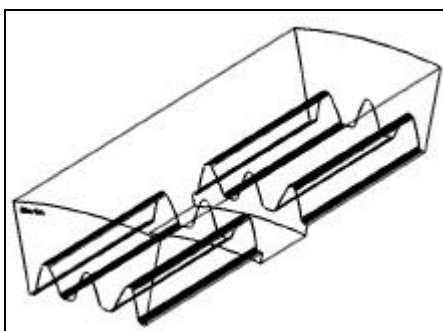

Gear Coupling

- Outer polyamide resin sleeve is manufactured from semi-crystalline engineering polymer with high molecular weight by injection moulding;
- Mould with high polishing allow low friction rotation;
- Smooth rounded tooth bottom minimize notching stresses;
- Tip relief on tooth allow smooth gearing;
- Small size, weight and low inertia;
- Silent operation and elastic absorption of shocks and vibration;
- Resistance to most common chemical agents and also to moderate heat;
- Maintenance-free due to self-lubrication of plastic material;
- Axial plug-in for easy assembling;
- Operating range -25°C to + 100°C

Warning & Safety Reminder

The logo for Martin Sprocket & Gear, Inc., featuring the word "Martin" in a stylized, white, cursive font on a black rectangular background.

WARNING & SAFETY REMINDER

Safety must be considered a basic factor in machinery operation at all times. Most accidents are the result of carelessness or negligence. All rotating power transmission products are potentially dangerous and must be guarded by the contractor, installer, purchaser, owner, and user as required by applicable laws, regulations, standards, and good safety practice. Additional specific information must be obtained from your local authorities; other sources may include the latest editions of American Society of Mechanical Engineers at 345 East 47th Street, New York, NY 10017 (+1-212-705-7722)

It is the responsibility of the contractor, installer, purchaser, owner, and user to install, maintain, and operate the parts or components manufactured or supplied by *Martin* Sprocket & Gear, Inc., in such a manner as to comply with the requirements of your local laws, ordinances, regulations, authorities, and safety acts which are similar in spirit and intention of the Williams-Steiger Occupational Safety Act in the USA as well as the American National Standard Institute Safety Code.

CAUTION

Guards, access doors, and covers must be securely fastened before operating any equipment.

If parts are to be inspected, cleaned, observed, or general maintenance performed, the following precautions must be taken.

1. Isolate the power source from the equipment.
2. Disconnect or reconnect any equipment only if the construction is fully visible and understood.
3. Wear eye protection.
4. Wear appropriate protective clothing, hats, gloves and safety shoes as warranted by the circumstances.
5. Check that all tools are used in good working condition only.
6. Loosen tensioning devices carefully.
7. Avoid sudden and unexpected movement of parts of the equipment and/or components.
8. Do not reuse individual components.
9. Do not reuse a damaged or faulty part.

Failure to follow these measures may result in personal injury or property damage.

WARNING

NOTE: CATALOG DIMENSIONS

Every effort is made to keep all catalog dimensions and styles current in the catalog. However, from time to time it is necessary because of manufacturing changes to alter stock products dimensionally.

If any stock product dimension or style shown in this catalog is critical to your application please consult factory for verification.